

Hustler® Parts Manual



HUSTLER®
TURF EQUIPMENT

200 South Ridge Road

Hesston, Kansas

67062



NOTICE OF REQUIREMENT OF SPARK ARRESTER MUFFLER

This equipment may create sparks that can start fires around dry vegetation. California Public Resources Code Section 4442.6 provides that it is unlawful to use or operate an internal combustion engine on any forest-covered, brush-covered, or grass-covered land unless the engine is equipped with a spark arrester maintained in effective working order. A spark arrester is a device constructed of nonflammable materials specifically for the purpose of removing and retaining carbon and other flammable particles over 0.0232 of an inch in size from the exhaust flow of an internal combustion engine that uses hydrocarbon fuels or which is qualified and rated by the United States Forest Service. Other states or federal areas may have similar laws. The Operator Should Contact Local Fire Agencies For Laws or Regulations Relating to Fire Prevention Requirements. **THIS EQUIPMENT DOES NOT HAVE A SPARK ARRESTER AND YOU SHOULD CONTACT YOUR AUTHORIZED DEALER FOR THE PURCHASE OF A SPARK ARRESTER.**

Inspect spark arrester daily; replace every 500 hours or as needed.

The Engine Owner's Manual provides information regarding the U.S. Environmental Protection Agency (EPA) and the California Emission Control Regulation of emission systems, maintenance and warranty.

Keep Engine Owner's Manual with your unit. Should the Engine Owner's Manual become damaged or illegible, replace immediately. Replacements may be ordered per the information found in the Product Information section of the owner's manual.

Federal law and California State law prohibit the following acts or the causing thereof:

1. The removal or rendering inoperative by any person other than for purposes of maintenance, repair, replacement, of any device or element of design incorporated into any equipment for the purposes of emissions control prior to or after its sales or delivery to the ultimate purchaser or while it is in use, or
2. The use of the equipment after such device or element of design has been removed or rendered inoperative by any person.

General Information	1
Frame, Footrest & Engine Guard	
Frame	3-1
Footrest & Floorpan	3-2
Engine Guard & Hitch	3-3
Transmissions, Drive Belt, Steering & Brake	
Transmission Assembly & Drive Belt	4-1
Transmission Service Parts - 605234	4-2
Transmission Service Parts - 605235	4-3
Steering & Brake (Multi-Page)	4-4
Steering Assembly Breakdown	4-5
Steering Box Assembly Breakdown	4-6
Wheels & Tires	
Wheels & Tires	5-1
Front Wheel Assembly Breakdown - 13" X 6.5" Tire	5-2
Drive Wheel Breakdown	5-3
Engine, Clutch & Fuel System	
Engine, Muffler & Clutch (Multi-Page)	6-1
Engine Service Parts	6-2
Fuel System—S/N 18114075 & Higher (Multi-Page)	6-3
Fuel System - S/N 18080150–18114074 (Multi-Page)	6-4
Fuel System - S/N Prior to 18080150 (Multi-Page)	6-5
Instrument Panel, Wire Harness, Fenders & Battery	
Instrument Panel & Wire Harness	7-1
Fenders & Battery	7-2
Deck, Deck Belt, Blades & Deck Lift	
Service Deck	8-1
Deck Pulleys & Spindles	8-2
Spindle Service Parts - 605380	8-3
Deck Belt, Discharge Chute, Pulley Covers, & Blades	8-4
Deck Lift & Deck Mounting Hardware (Multi-Page)	8-5
Seat & ROPS	
Seat	9-1
Seat Service Parts - 607457	9-2
ROPS	9-3

General Information

Note: When ordering parts, you must use the part number as shown for each part, not the index number. Always give the model and serial number to your parts and service representative.

Note: Items sold in bulk such as seals and hoses are sold by the foot.

Using This Manual

This manual is part of a service package for the Hustler® mowers. Use of this manual in conjunction with other Hustler® mower and component manuals will provide the information necessary to service and maintain Hustler® mowers.

This Parts Manual provides a complete parts listing for the unit. Use this manual when ordering parts. Illustrations used were current at the time of printing, but subsequent production changes may cause your machine to vary slightly in detail. Excel Industries, Inc. reserves the right to redesign and change the machine as deemed necessary, without notification. If a change has been made to your machine which is not reflected in this parts manual, see your authorized dealer for current information and parts.

The Service Manual is a service guide for use by Service Technicians. It provides the necessary information needed to perform normal maintenance requirements on these units.

The Operator's Manual provides fundamental operational information and operational safety that is needed when operating the mower.

The component manuals are furnished by the various manufacturers to be used for the troubleshooting and servicing of their products.

Hardware Description Codes & Abbreviations

The following codes are used throughout this parts manual. Refer to this list when ordering parts.

ABBREVIATION	DESCRIPTION	ABBREVIATION	DESCRIPTION
CB	CARRIAGE BOLT	MB	MACHINE BUSHING
CE	CLEVIS PIN	MS	MACHINE SCREW
CN	CLIP NUT	NT	NUT
CP	COTTER PIN	SC	SELF TAPPING CAP SCREW
CS	CAP SCREW	SH	SOCKET HEAD
CW	CUP WASHER	SB	SHOULDER BOLT
FDRW	FENDER WASHER	SS	SET SCREW
FW	FLAT WASHER	OD	OUTSIDE DIAMETER
HX	HEX HEAD	ID	INSIDE DIAMETER
LW	LOCK WASHER	WN	WELD NUT

Standard Torques

The following chart lists the standard torque values for the threaded fasteners found in this manual. Torque all cap screws, nuts and set screws to these values unless a different torque is shown in the Notes section next to the fastener.

SIZE	FT-LBS	N•M	SIZE	FT-LBS	N•M
.250	8.2	11.1	M3	1	1.3
.312	17	23	M4	2.2	3
.375	30	40	M5	4.5	6.1
.438	48	65	M6	7.7	10.4
.500	73	99	M8	18.5	25
.562	105	143	M10	37	50
.625	145	200	M12	64	87
.750	260	350	M14	80	108.5
.875	420	565	M16	160	215
1.00	625	850	M20	320	435
			M24	555	750

Pagina lasciata volutamente in bianco

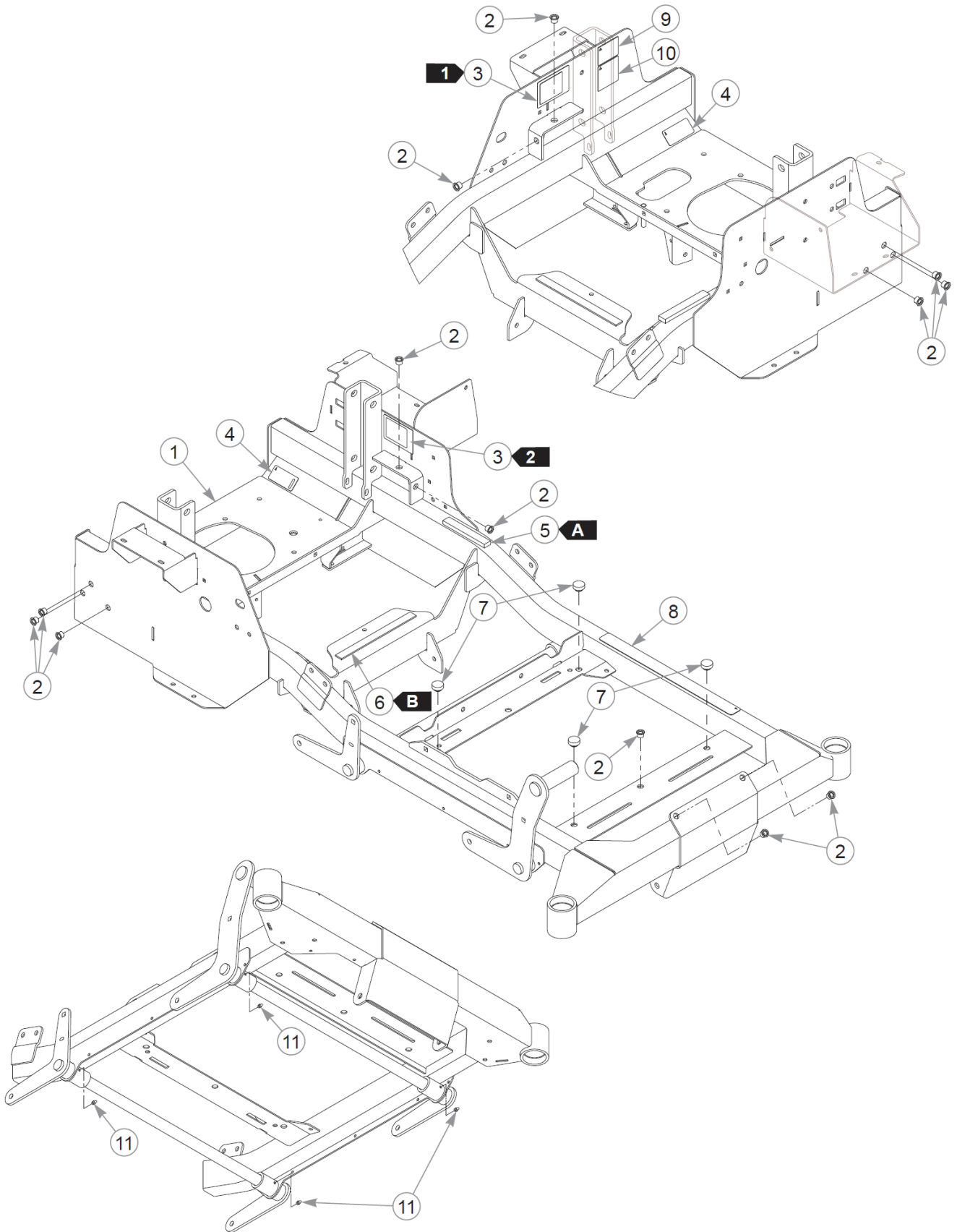

Elemento	Parte n.	Q.ta	Nome
1	554676	1	SVC FRAME
2	808493	13	RIVET NUT, 3/8-16 THREA
3	N/A	2	SERIAL NUMBER / SPEC DECAL
4	602041	2	DECAL, HOT
5	713198	13 cm	SEAL 3/8x3/4 SOLD BY FT
6	033035	23 cm	WEATHERSTRIP .12X.75
7	781880	4	BUMPER, .500x 1.00x .31
8	601993	1	DECAL, SAFE OPERATION
9	776310	1	DECAL, CE MARK
10	789776CE	1	DBA LIMIT DECAL
11	015495	4	GREASE FITTING STRAIGHT

Comments for Page: Frame

1. Serial number decal. In the event the serial number decal becomes damaged or illegible, please contact your dealer to order a replacement.
2. EPA compliance decal (does not apply to mowers with serial numbers prior to 19010000).
3. The frame includes the decals and hardware.

SEAL/WEATHERSTRIP LENGTHS

A: 13 cm

B: 23 cm

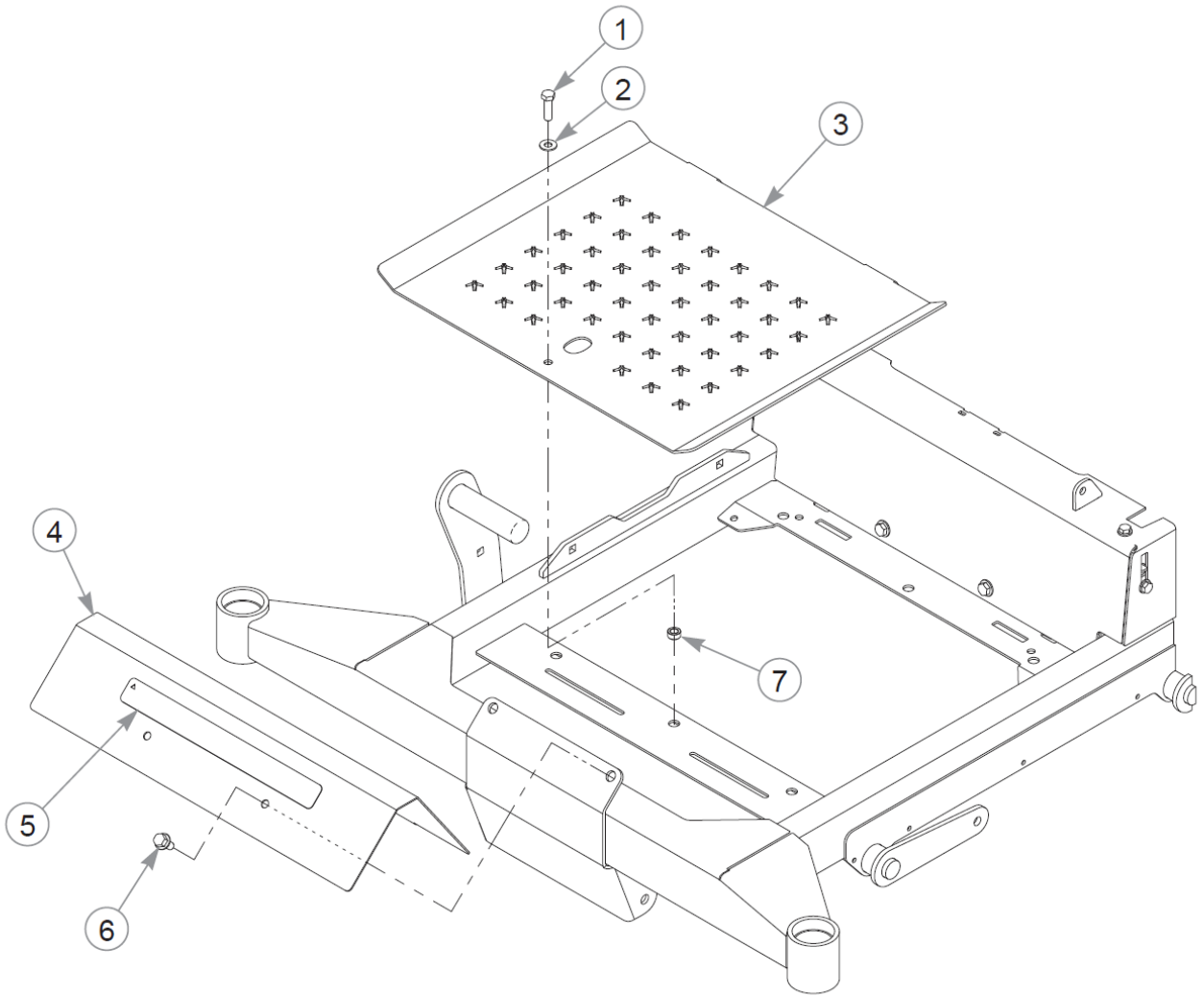

Footrest & Floorpan

48" FasTrak Parts Manual - 938704CE - HTFSTS048KAWFR691VC

Elemento	Parte n.	Q.ta	Nome
1	052860	3	CS .375-16X1.25 HX G5 ZY
2	767954	1	FW 0.379X.82X.06 HD ZY
3	124567-1	1	FLOOR PAN
4	554682	1	SVC FOOT REST
5	602407	1	DECAL, HUSTLER ID
6	029629	2	CS .375-16X0.75 HXF G5ZY
7	118900	1	SPACER, DECK LIFT LINK

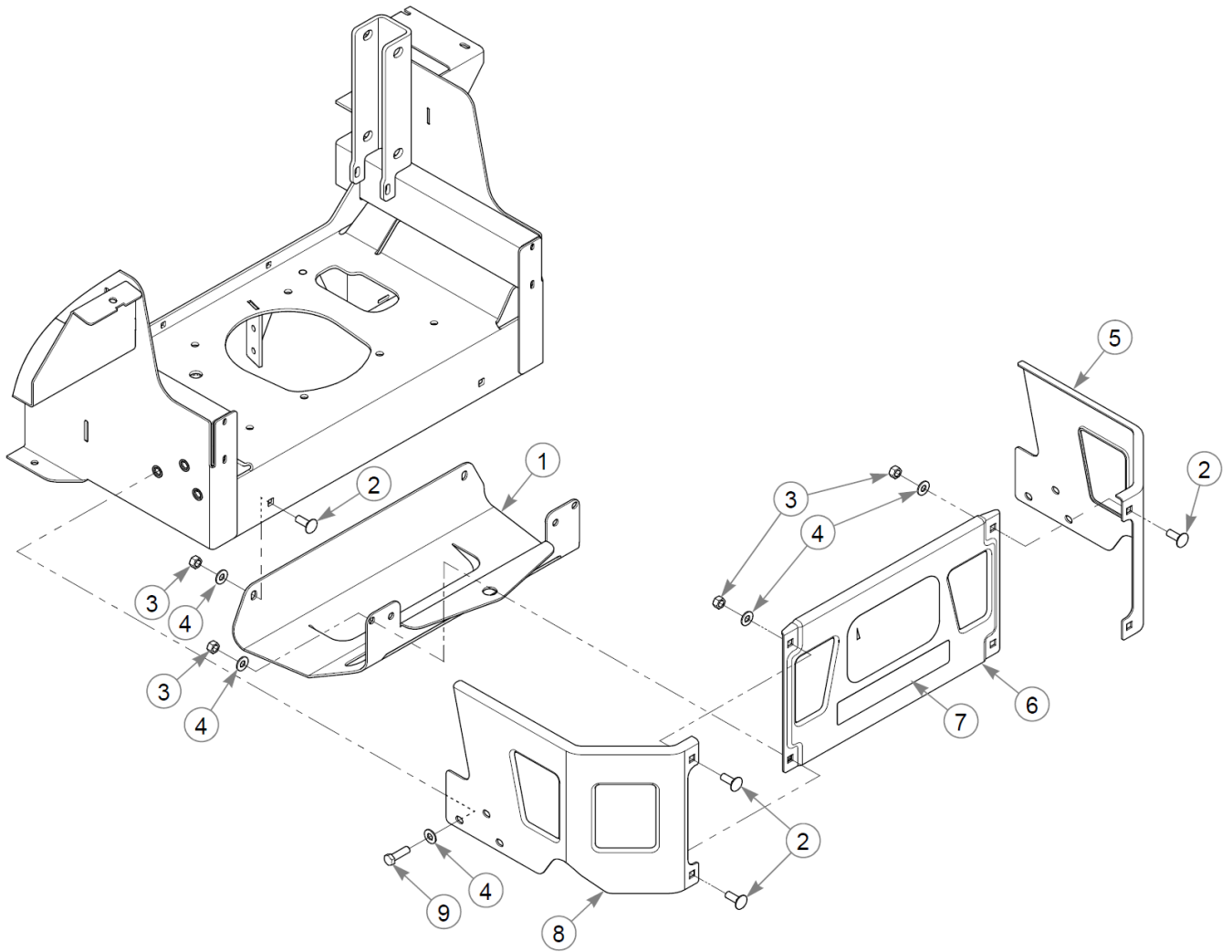

Engine Guard & Hitch

Elemento	Parte n.	Q.ta	Nome
1	119977	1	HITCH PLATE
2	025395	6	CB .375-16X 1.00 G5 ZNY
3	054502	6	NT .375-16HXG5
4	767954	12	FW 0.379X.82X.06 HD ZY
5	121134	1	GUARD, RH
6	553123	1	SVC PART, STAMPED BUMPER
7	604770	1	DECAL, "H" LOGO
8	121133	1	GUARD, LH
9	052860	6	CS .375-16X1.25 HX G5 ZY

Comments for Page: Engine Guard & Hitch

1. The center guard includes the decal.

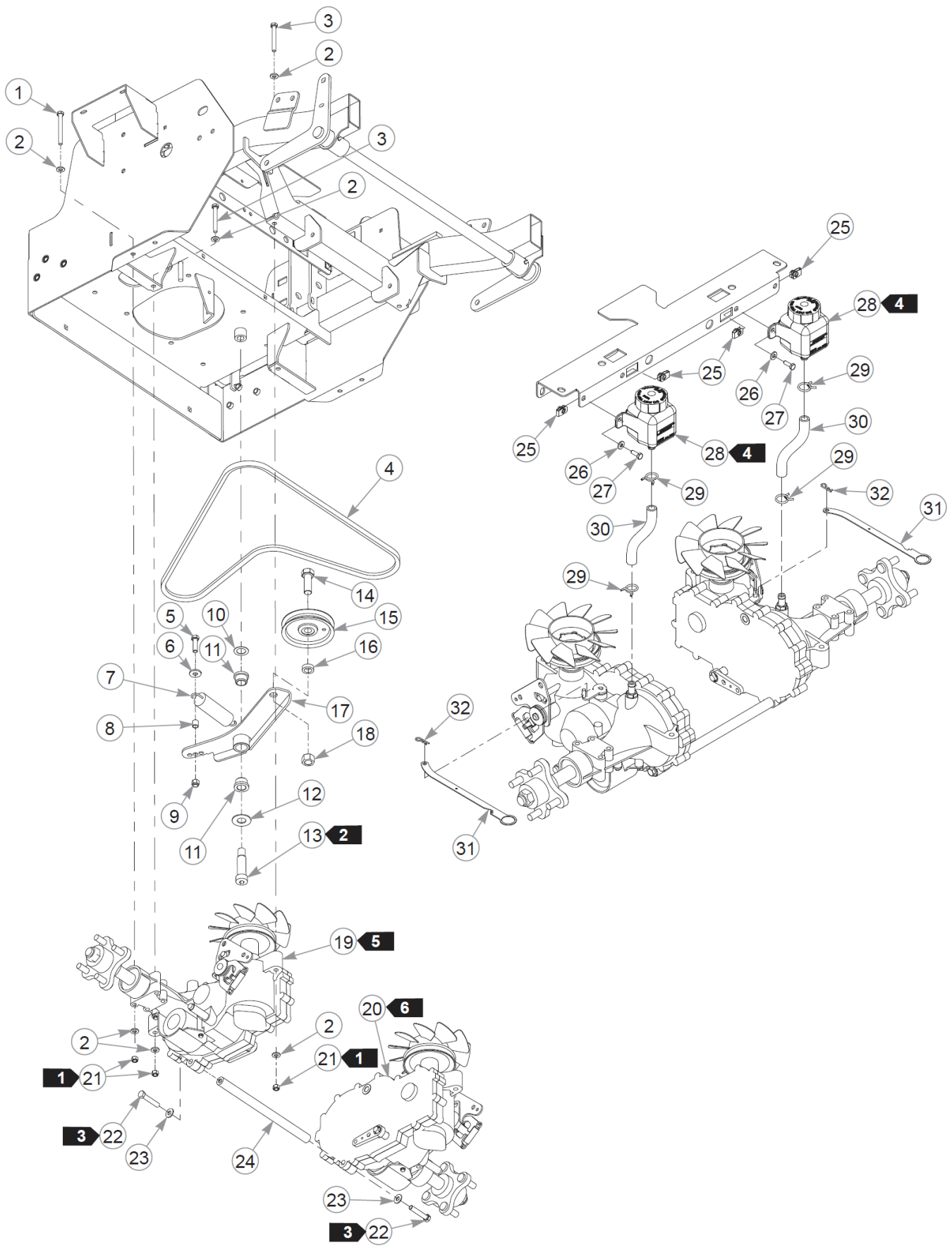

Elemento	Parte n.	Q.ta	Nome
1	043067	4	CS .312-18X3.000HXG5
2	768523	16	FW 0.343SAE
3	710087	4	CS .312-18X2.500HXG5
4	605468	1	BELT, A 67.07" EL (DRIVE BELT)
5	052860	1	CS .375-16X1.25 HX G5 ZY
6	712919	1	FW 0.406X1.00X.12 HD ZY
7	036384	1	SPRING 1/4 COIL PL 1.23
8	605481	1	BUSHING
9	086660	1	NT .375-16NLG8
10	704791	1	FW .781X1.25X.02 ZY
11	781153	2	BUSHING, UHMW
12	025296	1	FW .760X1.63X0.08 ZY
13	601084	1	SB .750X 2.000 SH.625-11
14	025007	1	CS .62511X1.750HXG5
15	786848	1	PULLEY, IDLER 4"od x .6
16	600296	1	SPACER, DECK IDLER
17	122722	1	KIT, TENSION ARM
18	016972	1	NT .625-11 HX G5 ZNYC
19	605235	1	ZT3100, 24.74:1 RH
20	605234	1	ZT3100, 24.74:1 LH
21	058776	8	NT .312-18NLG5
22	016410	2	CS .375-16X2.000HXG5
23	767954	2	FW 0.379X.82X.06 HD ZY
24	600987	1	ZT SPACER TUBE
25	601982	4	CN .250-20X .150 MAX THK
26	768515	4	FW 0.281SAE
27	055939	4	CS .250-20X0.75 HX G5 ZY
28	605217	2	RESERVOIR, SINGLE FTNG
Not Shown	600767	2	CAP, OVERFLOW TANK
29	601001	4	SPRING CLAMP, .75" DIA
30	605218	2	OVERFLOW HOSE, FST
31	120126	2	LINK, TOW VALVE
32	706549	2	HP0.080X1.190

Comments for Page: Transmission Assembly & Drive Belt

1. Torque to 23 N•m.
2. Torque to 135 N•m.
3. Torque to 41 N•m.

Transmission Assembly & Drive Belt

48" FasTrak Parts Manual - 938704CE - HTFSTS048KAWFR691VC

4. 605217 (reservoir) includes the cap (600767).
5. Right Side Transmission
6. Left Side Transmission

Pagina lasciata volutamente in bianco

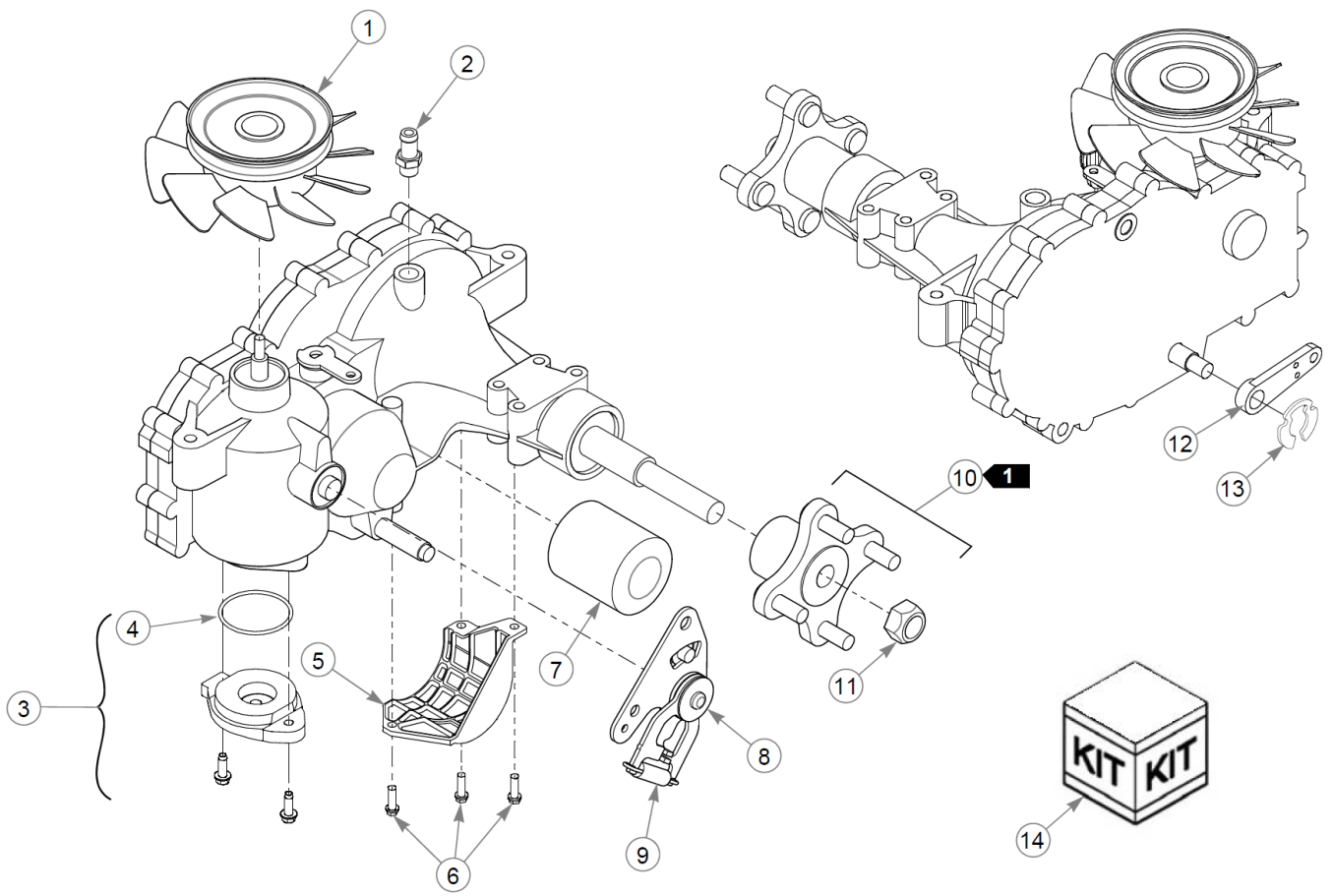

Elemento	Parte n.	Q.ta	Nome
1	601941	1	FAN/PULLEY KIT
2	605608	1	FITTING, TRANSMISSION
3	603572	1	COVER, ZT3100 CHRG PUMP
4	603223	1	O-RING, ZT28/3100 CHARGE
5	600975	1	GUARD, TRANS FILTER
6	604324	3	CS .250-20 X .75 HX FLG
7	600976	1	FILTER, OIL (HYDRAULIC OIL FILTER)
8	605778	1	RTN, LEFT
9	604903	1	HG RTN SPRING
10	601433	1	KIT, HUB 4 BOLT
<p>Commenti per num parte 601433</p> <p>CUSTOMER SERVICE NOTE: Lug Studs are not sold separately.</p>			
11	788877	1	NUT, H-G ZT HUB
12	601221	1	ZT2800 BRAKE ARM - 2007
13	600972	1	CLIP, RETAINING
14	606830	1	OIL RETENSION KIT,
Not Shown	607199	1	SEAL KIT 72994 HYDRO-G

Comments for Page: Transmission Service Parts - 605234

1. Hub kit (601443) includes the nut (788877).

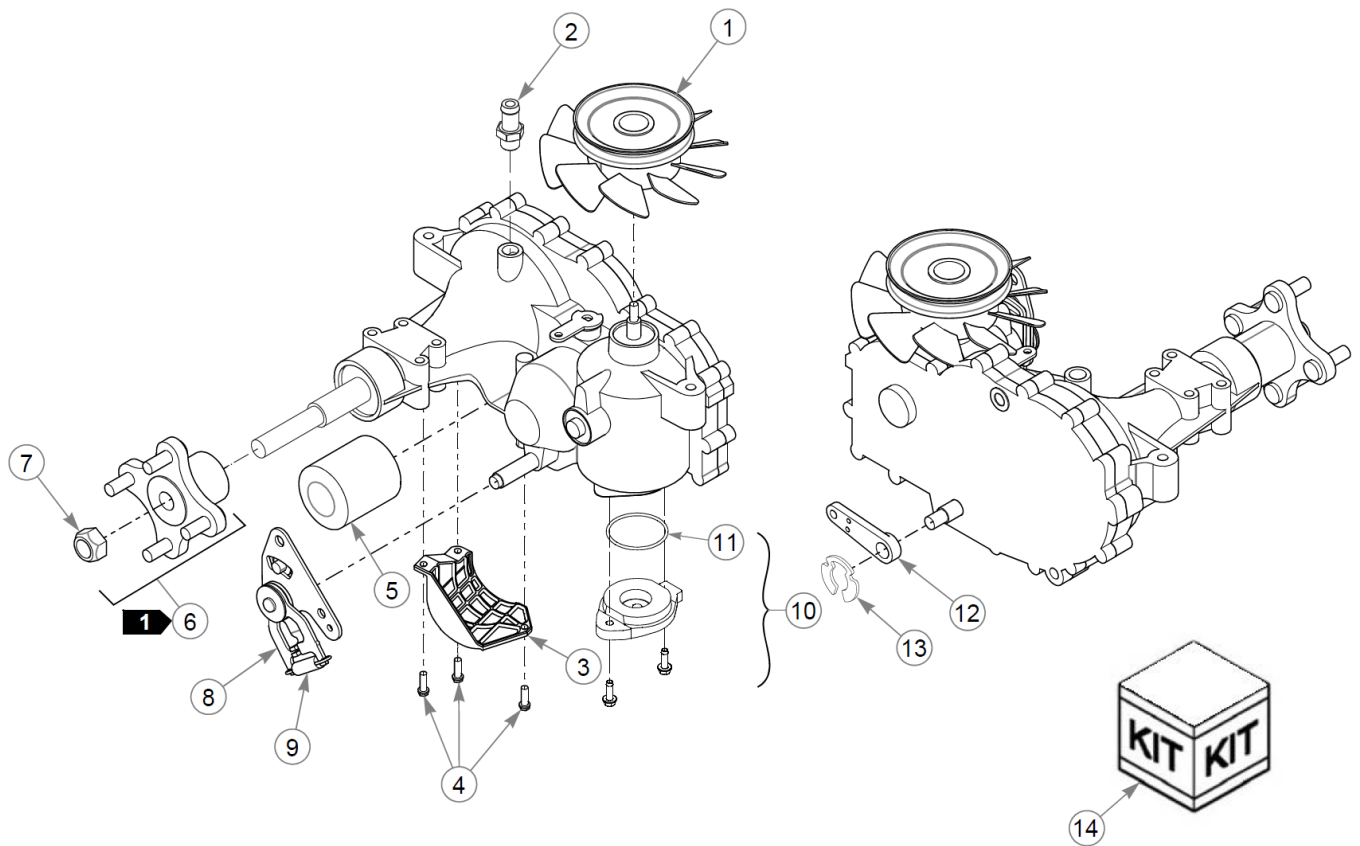

Elemento	Parte n.	Q.ta	Nome
1	601941	1	FAN/PULLEY KIT
2	605608	1	FITTING, TRANSMISSION
3	600974	1	GUARD, TRANS FILTER
4	604324	3	CS .250-20 X .75 HX FLG
5	600976	1	FILTER, OIL (HYDRAULIC OIL FILTER)
6	601433	1	KIT, HUB 4 BOLT
<p>Commenti per num parte 601433</p> <p>CUSTOMER SERVICE NOTE: Lug Studs are not sold separately.</p>			
7	788877	1	NUT, H-G ZT HUB
8	605779	1	RTN, RIGHT
9	604903	1	HG RTN SPRING
10	603572	1	COVER, ZT3100 CHRGR PUMP
11	603223	1	O-RING, ZT28/3100 CHARGE
12	601221	1	ZT2800 BRAKE ARM - 2007
13	600972	1	CLIP, RETAINING

Comments for Page: Transmission Service Parts - 605235

1. Hub kit (601443) includes the nut (788877).

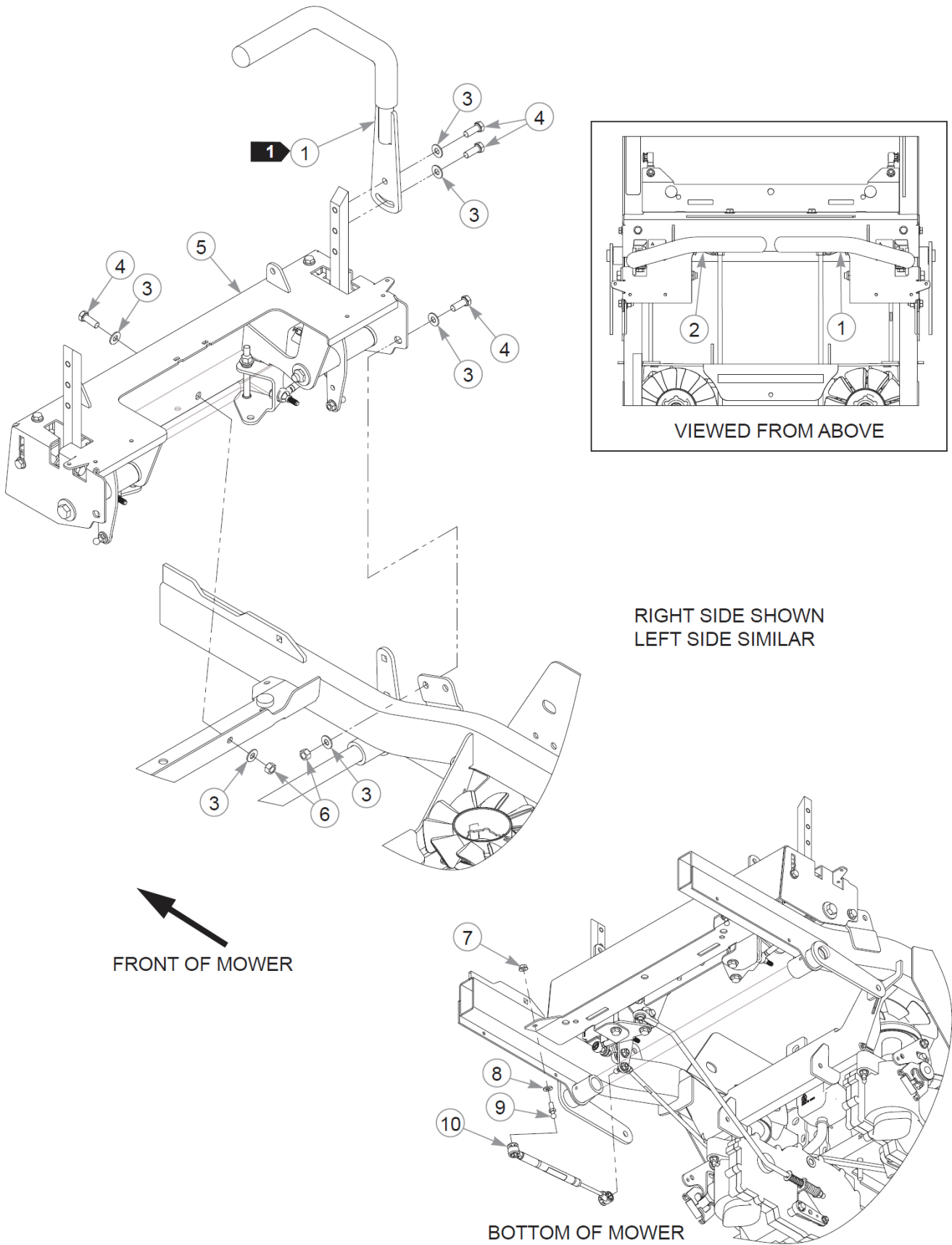

Steering & Brake (Multi-Page)

48" FasTrak Parts Manual - 938704CE - HTFSTS048KAWFR691VC

Elemento	Parte n.	Q.ta	Nome
1	605383	1	STEERING BAR W/A
Not Shown	781260	1	GRIP, STEERING BAR
2	605384	1	STEERING BAR W/A, LH
Not Shown	781260	1	GRIP, STEERING BAR
3	767954	20	FW 0.379X.82X.06 HD ZY
4	036244	8	CS .375-16X1.00 HX G5 ZY
5	N/A	1	STEERING ASSEMBLY
6	054502	4	NT .375-16HXG5
7	016832	2	NT .312-18FLKG5
8	768523	10	FW 0.343SAE
9	781922	2	BALL STUD
10	603983	2	DAMPER
11	605591	1	DECAL, FASSTRAK
12	086660	4	NT .375-16NLG8
13	605145	2	BRAKE ROD ASSEMBLY
14	080655	2	CS .375-16X1.500HXG5
15	601131	2	SPRING, BRAKE ARM RET.
16	601051	2	OVERTRAVEL SPRING
17	016816	2	NT .250-20FLKG5
18	120671	1	BRAKE SPRING LINK, RS
19	120672	1	BRAKE SPRING LINK, LS
20	055939	2	CS .250-20X0.75 HX G5 ZY
21	600981	2	PUMP ROD ASSEMBLY
22	023655	4	NT 0.312-24 NL G8
23	604456	2	SPACER, PUMP ARM

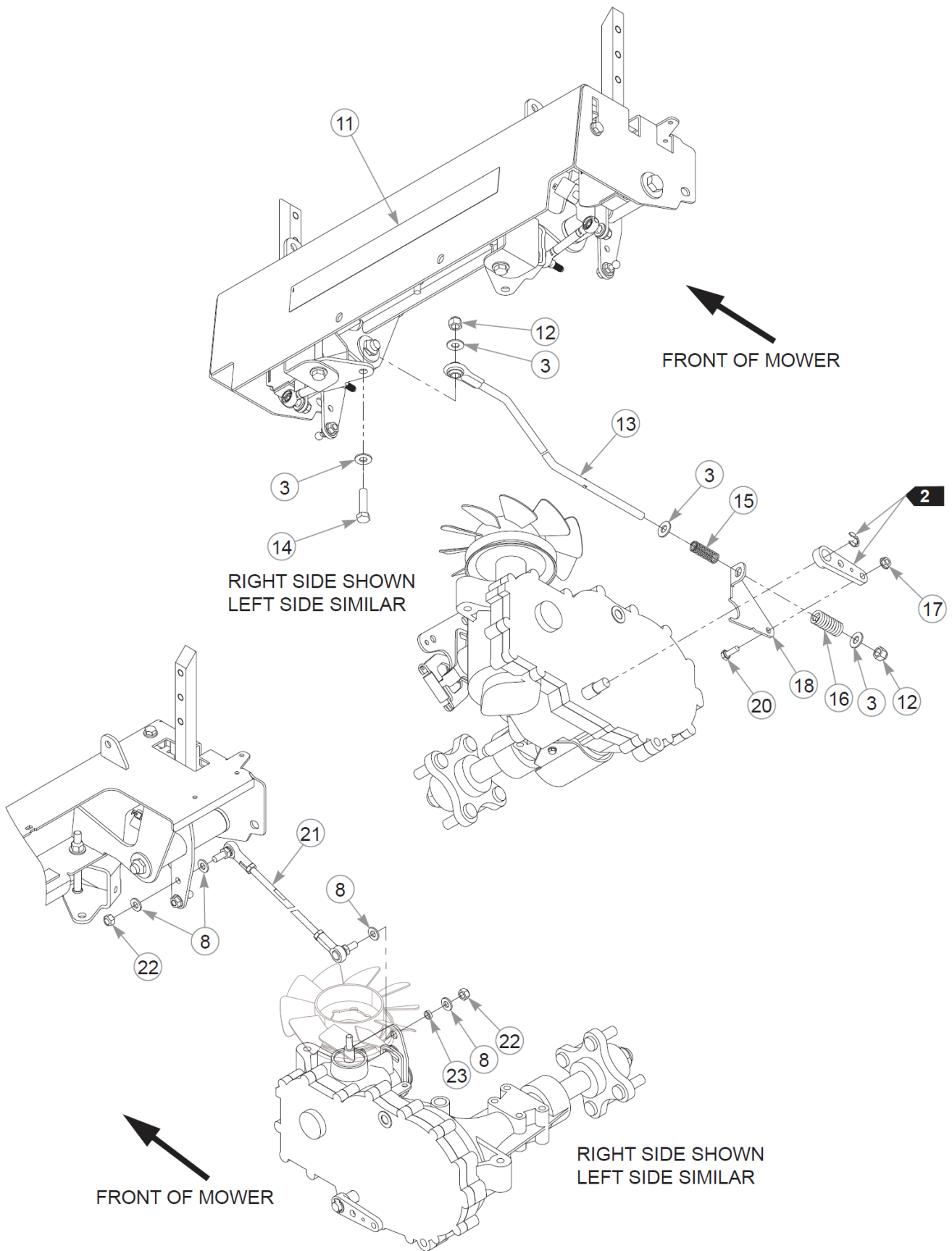

Steering & Brake (Multi-Page)

Comments for Page: Steering & Brake (Multi-Page)

1. The steering bars include the grips.
2. Part of the transmission.

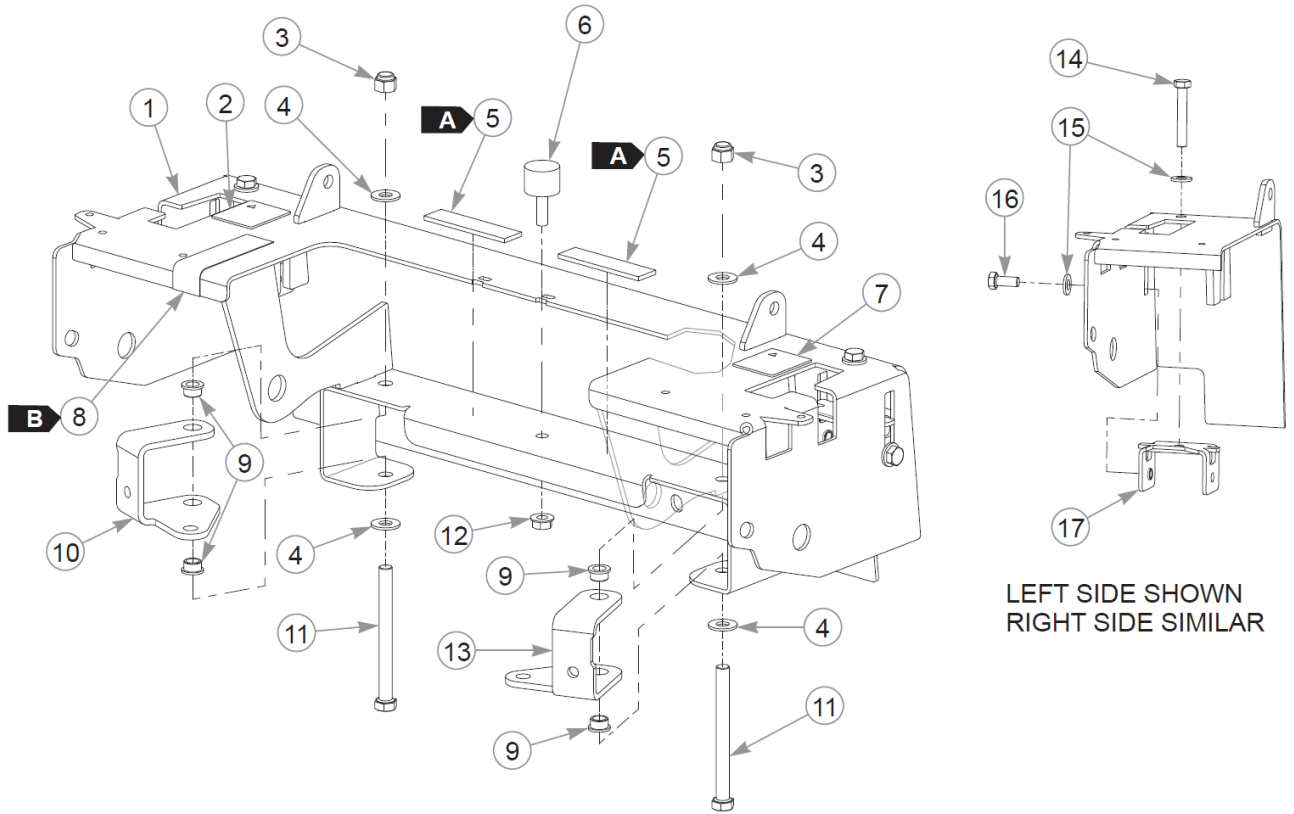

LEFT SIDE SHOWN
RIGHT SIDE SIMILAR

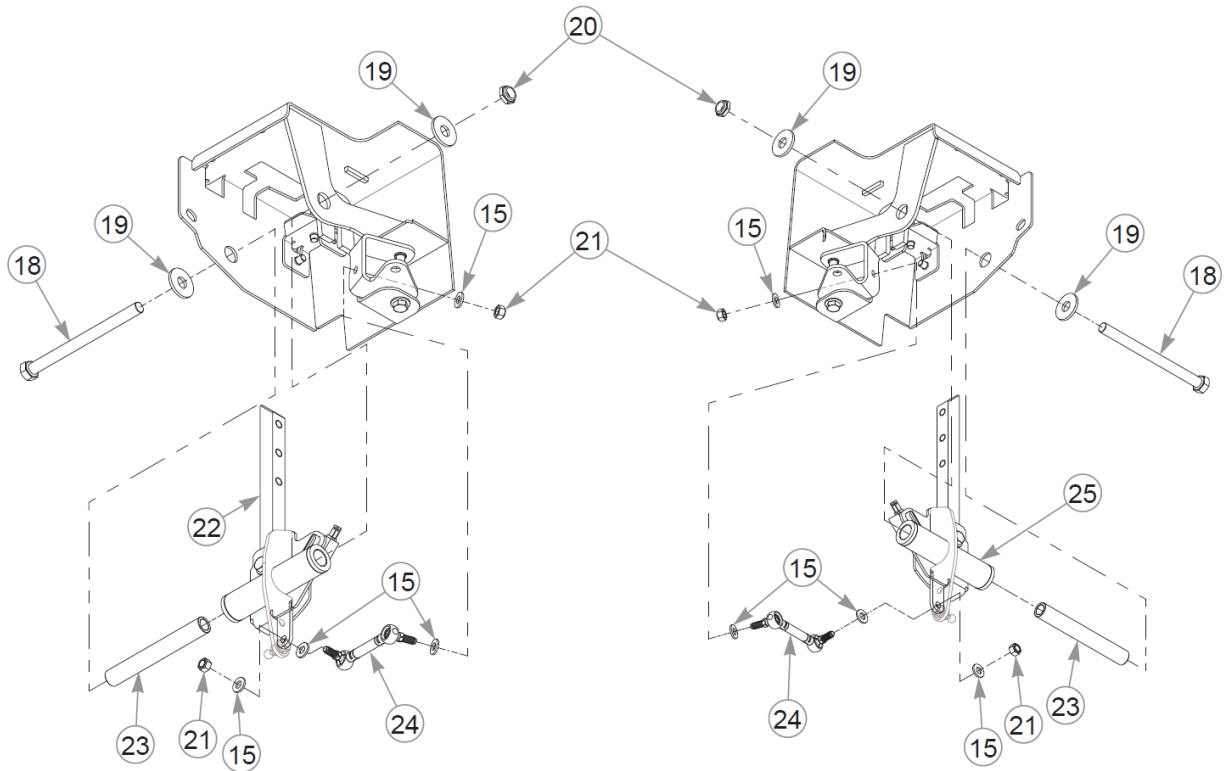

Steering Assembly Breakdown

Elemento	Parte n.	Q.ta	Nome
1	554684	1	SVC STEERING COVER
2	785139	1	DECAL, STEERING L.S.
3	086660	2	NT .375-16NLG8
4	767954	4	FW 0.379X.82X.06 HD ZY
5	033035	15 cm	WEATHERSTRIP .12X.75
6	605542	1	ISOLATOR
7	785220	1	DECAL, STEERING R.S.
8	607286	10 cm	PROTECTIVE TAPE 1"
9	765339	4	BUSHING,IGUS#0608 (FS)
10	124352-1	1	BRAKE BELL CRANK, LS
11	725796	2	CS .375-16X4.000HXG5
12	016832	1	NT .312-18FLKG5
13	124353-1	1	BRAKE BELL CRANK, RS
14	064345	2	CS .312-18X2.000HXG5
15	768523	12	FW 0.343SAE
16	034280	2	CS .312-18X0.750HXG5
17	605518	2	STOP, STEERING
18	042630	2	CS .500-13X6.500HXG5
19	712976	4	FW 0.531X1.38X.12 ZY
20	707398	2	NT .500-13 JAM NY LK
21	058776	4	NT .312-18NLG5
22	N/A	1	LS STEERING BOX SUB-ASSEMBLY
23	119811	2	SPACER, STEERING
24	604179	2	BRAKE LINK
25	N/A	1	RS STEERING BOX SUB-ASSEMBLY

Comments for Page: Steering Assembly Breakdown

1. The steering cover includes the decals.

WEATHERSTRIP & WEAR TAPE LENGTHS

A: 7.5 cm

B: 10.2 cm

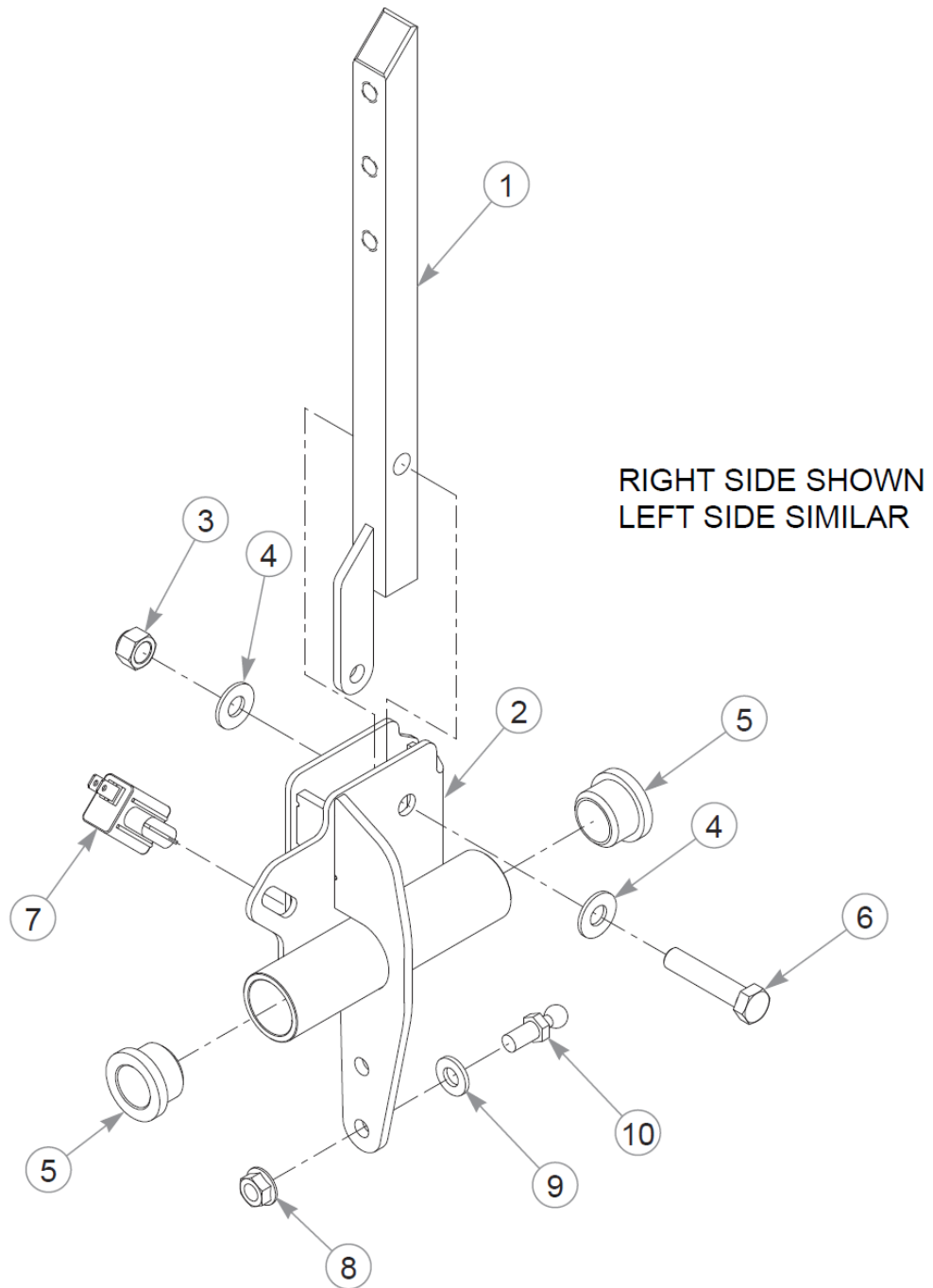

Steering Box Assembly Breakdown

48" FasTrak Parts Manual - 938704CE - HTFSTS048KAWFR691VC

Elemento	Parte n.	Q.ta	Nome
1	119807	1	STEER LEVER W/A
2	119750	1	STEER PIVOT W/A, RS
Not Shown	119749	1	STEER PIVOT W/A, LS
3	086660	1	NT .375-16NLG8
4	767954	2	FW 0.379X.82X.06 HD ZY
5	781153	2	BUSHING, UHMW
6	705178	1	CS .375-16X1.750HXG5
7	601087	1	SWITCH, PLUNGER N.O.
8	016832	1	NT .312-18FLKG5
9	768523	1	FW 0.343SAE
10	781922	1	BALL STUD

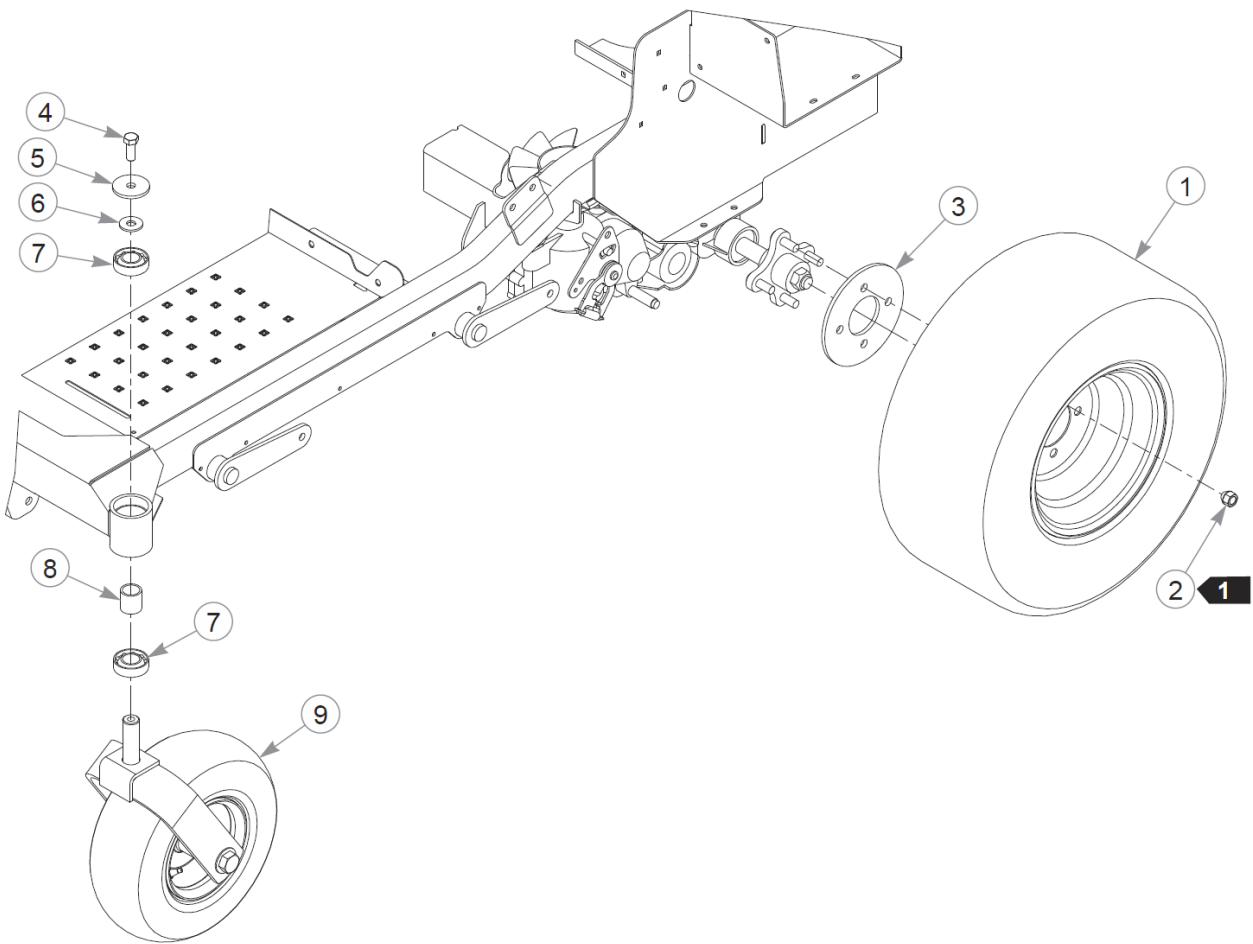

Wheels & Tires

Elemento	Parte n.	Q.ta	Nome
1	605484	2	TIR/WHL 22X9.50-10 SLV
2	061077	8	WHEEL NUT
3	111875-3	2	BACKUP PLATE, WHEEL
4	705954	2	CS .500-13X1.25 HX G5 ZY
5	344267	2	FW .510X2.15X.19 ZY
6	712976	2	FW 0.531X1.38X.12 ZY
7	784223	4	BEARING
8	784603	2	SPACER
9	N/A	1	FRONT TIRE ASSEMBLY

Comments for Page: Wheels & Tires

1. Torque to 88–102 N•m.

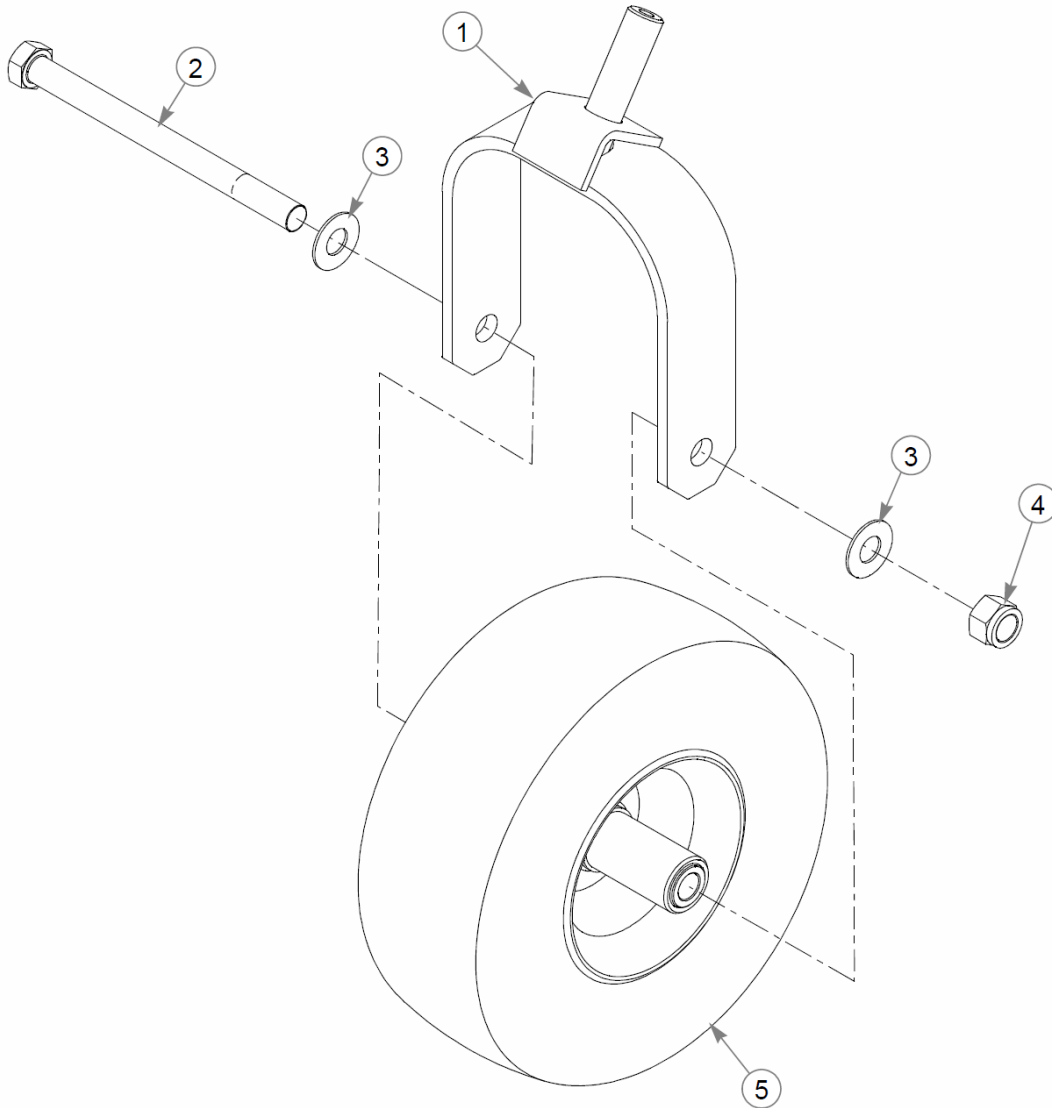
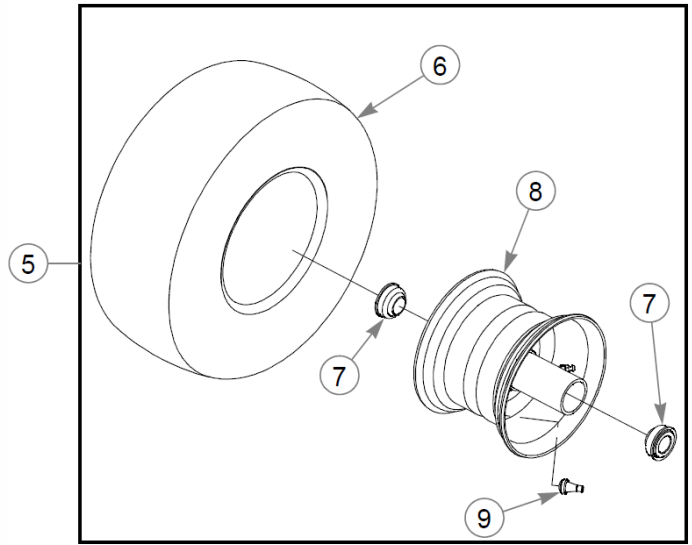

Elemento	Parte n.	Q.ta	Nome
1	604691	1	FORK W/A
2	041475	1	CS .750-10X9.50 HX G5 ZY
3	025296	2	FW .760X1.63X0.08 ZY
4	061101	1	NT .750-10 HX ZY NL GR B
5	605197	1	TIR/WHL 13X6.50-6 SLV
6	604843	1	TIR 13X6.50-6 B4R SMTH
REF	747741	1	TIR 13X6.50-6 B4R RIB
7	786103	2	WHEEL BEARING
8	605198	1	WHL 6X4.50 SLV
9	019521	1	TIRE VALVE TR-412 GOODY

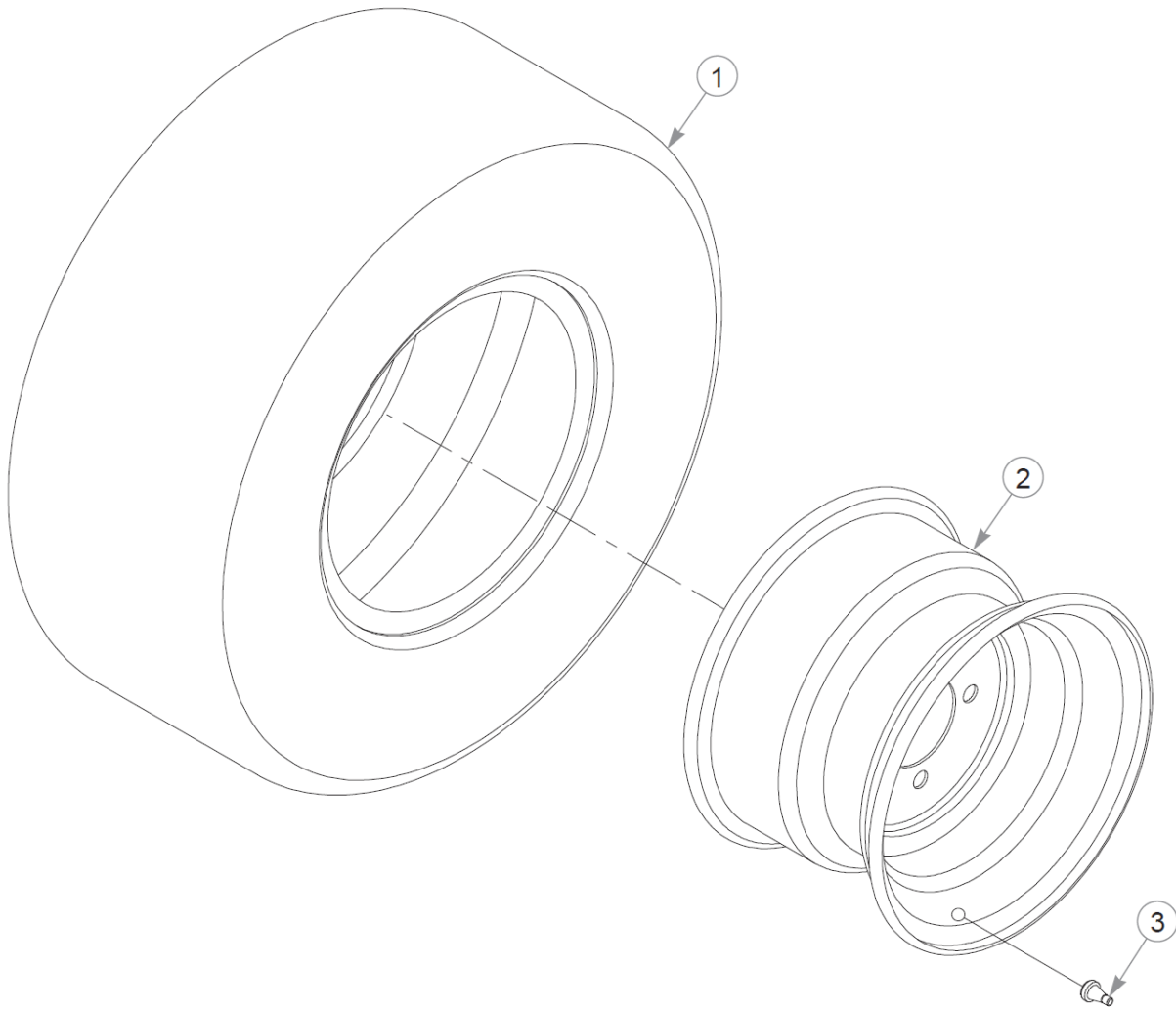

Drive Wheel Breakdown

48" FasTrak Parts Manual - 938704CE - HTFSTS048KAWFR691VC

Elemento	Parte n.	Q.ta	Nome
1	605485	1	TIR 22X9.50-10 B4R LTFT
2	600700	1	WHL 10X7.00 4X4.0 SLV
3	019521	1	TIRE VALVE TR-412 GOODY

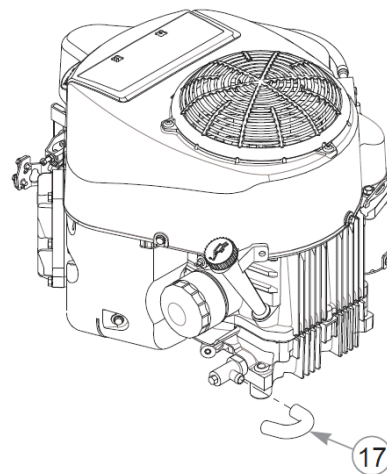
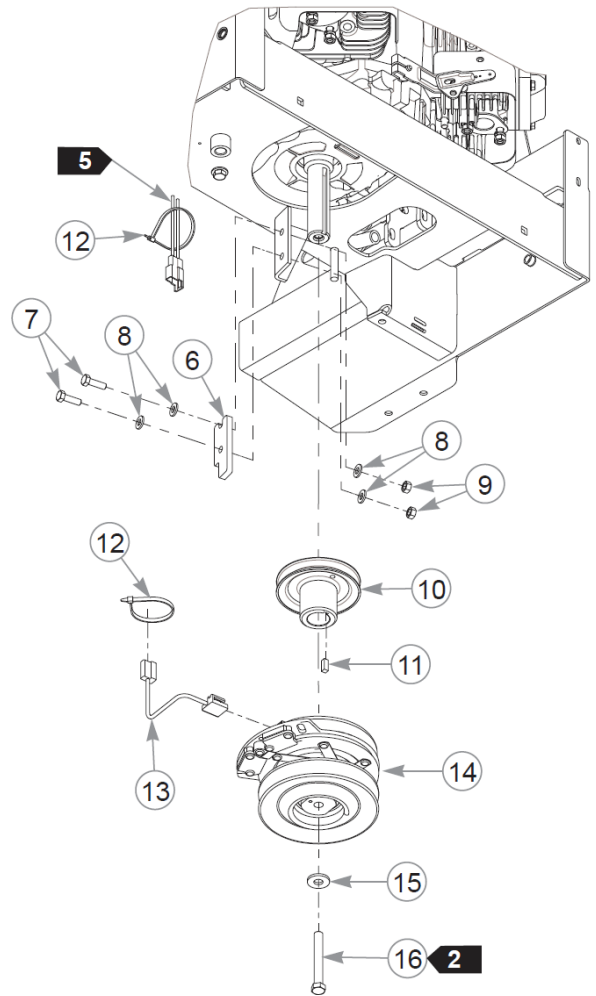
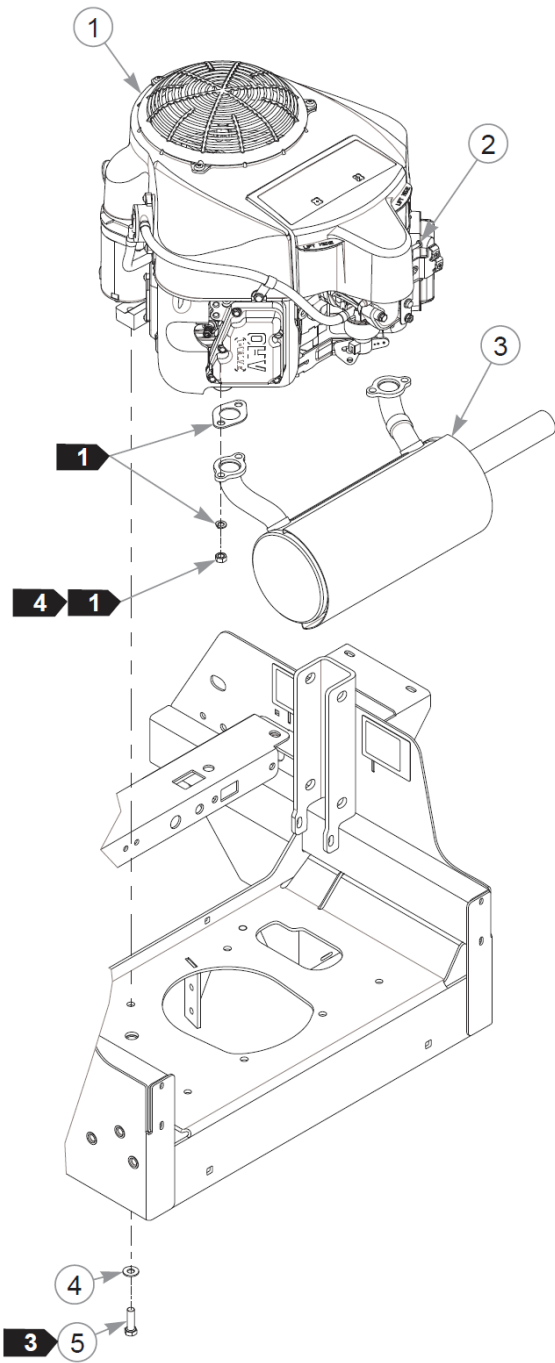

Elemento	Parte n.	Q.ta	Nome
1		1	ENGINE, KAW FR691V
2	603524	1	CS M5-0.8 X 50 MM
3	604250	1	MUFFLER
4	767954	4	FW 0.379X.82X.06 HD ZY
5	602580	4	CS .375-16X1.25HXG8ZYP85
6	113946	1	CLUTCH ANCHOR
7	036236	2	CS .312-18X1.250HXG5
8	768523	5	FW 0.343SAE
9	034272	2	NT .312-18HXG5
10	605490	1	PULLEY, ENG 4.58OP
11	712372	1	KEY 1/4 SQ X 0.66 LG(FS)
12	000331	5	WIRE TIE, SMALL/SHORT
13	791251	1	HARNESS, CLUTCH PIGTAIL

Commenti per num parte 791251

Pigtail was updated with epoxy to hold the wires steady. The wire sheath was also updated to a more flexible material.

14	121773K	1	CLUTCH KIT
15	602680	1	FW .453X1.12X.12 HRD ZY
16	601834	1	CS .437-20X3.25 HXG5 P85
17	605317	1	HOSE, OIL DRAIN
18	720516	1	CS M8-1.25X16HX FL10.9
19	601841	1	BATTERY CABLE, NEG.
20	029876	1	LW .312 INTEXT ZY
21	601840	2	BATTERY CABLE, POS.
22	601982	2	CN .250-20X .150 MAX THK
23	768515	4	FW 0.281SAE
24	064329	2	CS .250-20X0.625HXG5
25	030817	1	STARTER SOLENOID HW KIT
26	044255	1	NT #10-32HXG5
27	024927	2	NT .250-20HXG5
28	771428	1	BATTERY CBL BOOT-RED(FS)

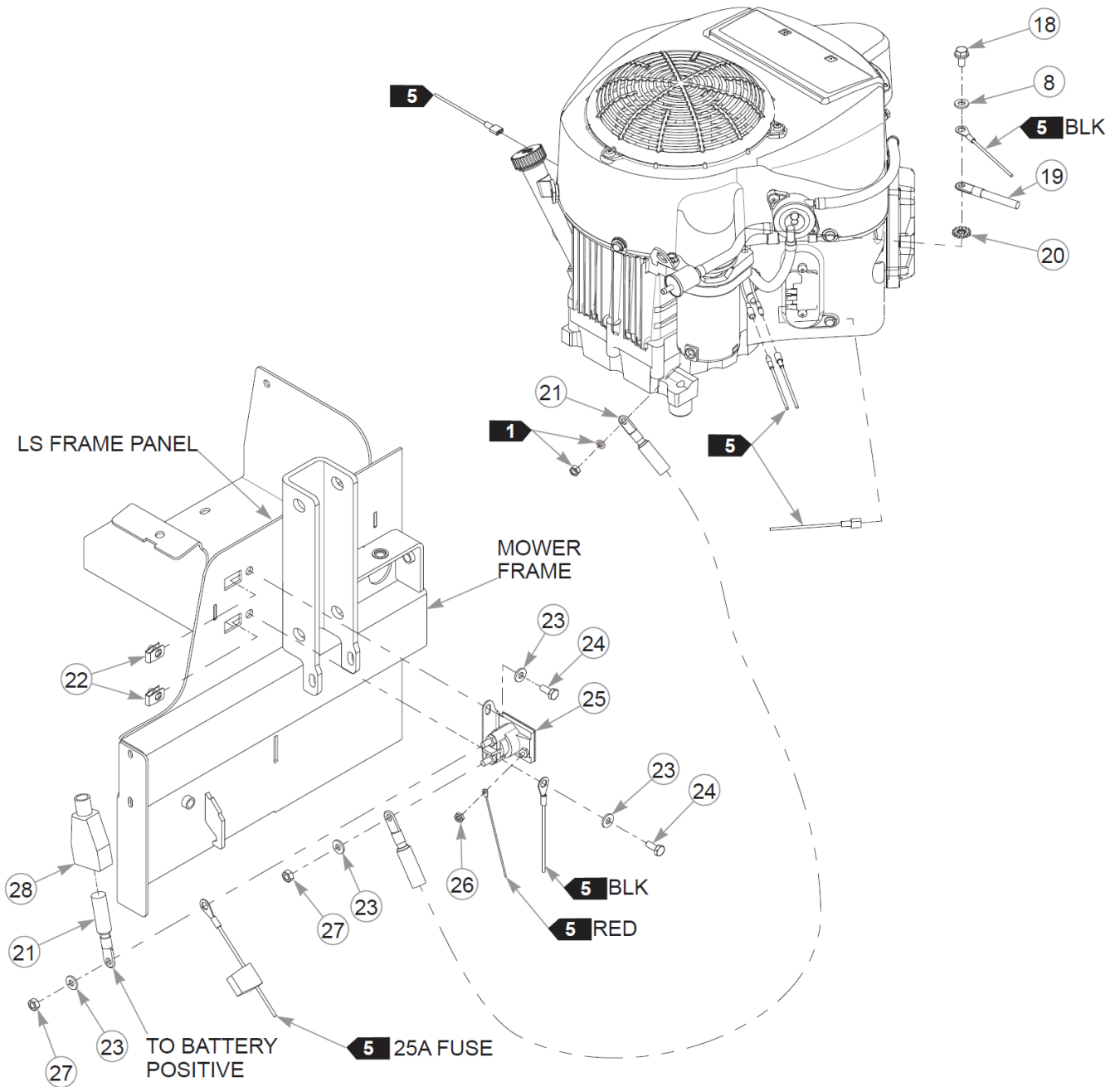

Engine, Muffler & Clutch (Multi-Page)

48" FasTrak Parts Manual - 938704CE - HTFSTS048KAWFR691VC

Comments for Page: Engine, Muffler & Clutch (Multi-Page)

1. Supplied with the engine.
2. Torque to 61 N•m.
3. Torque to 41–47 N•m.
4. Torque to 23 N•m.
5. Part of the wire harness.

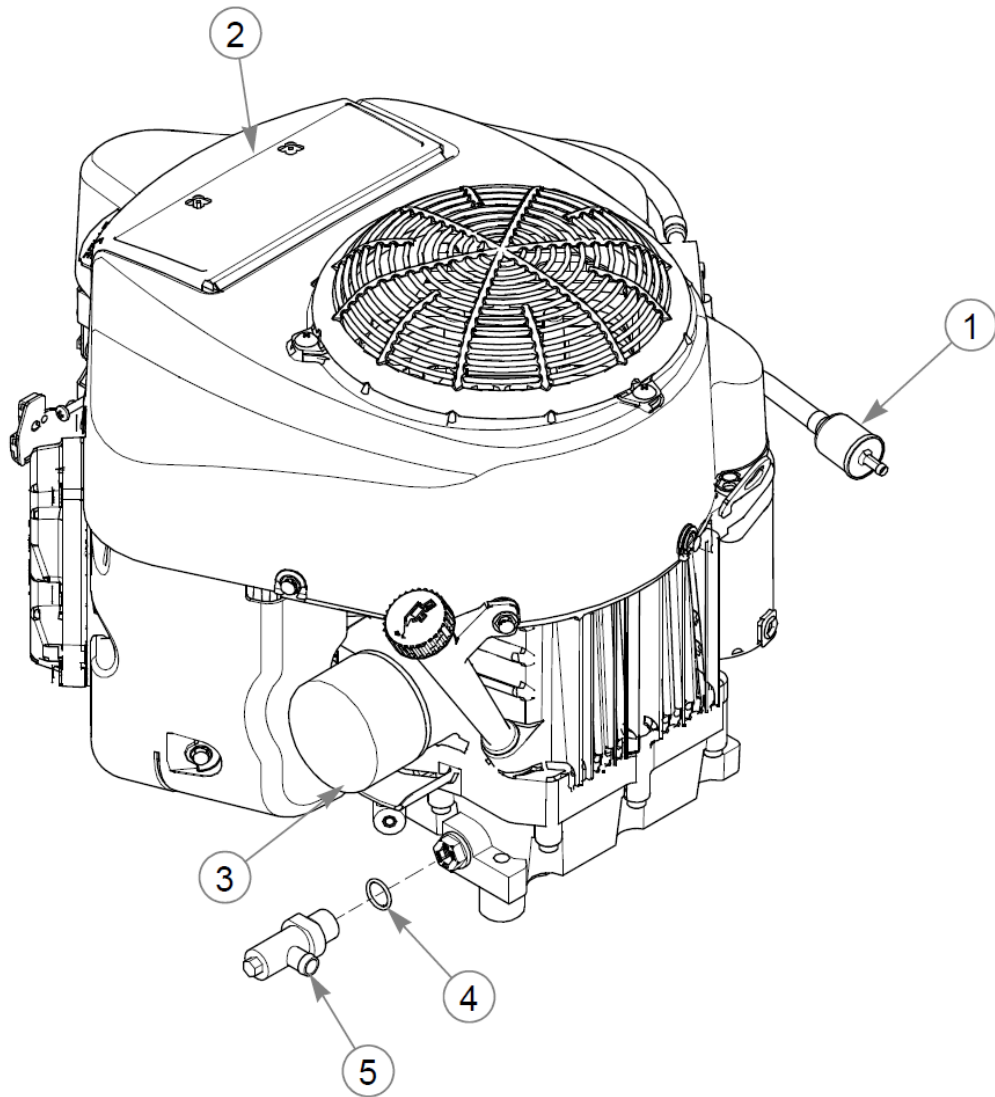

Engine Service Parts

Elemento	Parte n.	Q.ta	Nome
1	068478	1	FUEL FILTER
2	603059	1	AIR FILTER, KAW (MAIN AIR FILTER)
3	602581	1	FILTER, ENGINE OIL
4	604369	1	O-RING
5	604350	1	VALVE, OIL DRAIN

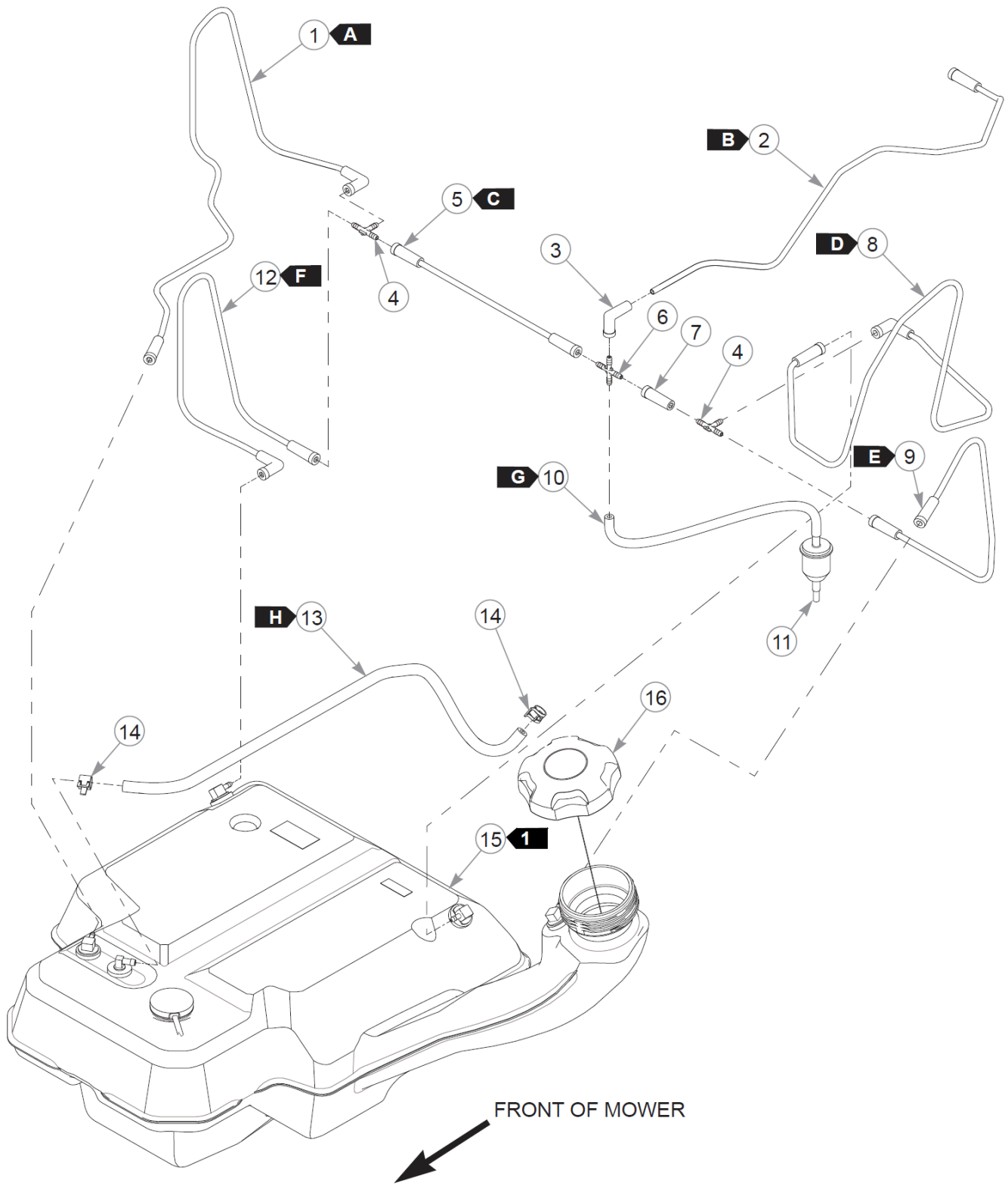

Elemento	Parte n.	Q.ta	Nome
1	605491	1	VAPOR LINE, 3/16 FORMED
2	605493	1	VAPOR LINE, 3/16 FORMED
3	605565	1	BOOT, 3/16 TO 3/16
4	605690	2	TEE, 3/16" PLASTIC
5	605535	1	VAPOR LINE, 3/16 FORMED
6	605425	1	CROSS, 3/16" PLASTIC
7	605564	1	BOOT, 3/16 TO 3/16
8	605534	1	VAPOR LINE, 3/16 FORMED
9	605492	1	VAPOR LINE, 3/16 FORMED
10	603326	31 cm	VAPOR LINE, 3/16"
<p>Commenti per num parte 603326</p> <p>Sold by the foot.</p>			
11	604323	1	FILTER, VAPOR SYSTEM
12	605533	1	VAPOR LINE, 3/16 FORMED
13	015818	58 cm	FUEL LINE, 1/4"
<p>Commenti per num parte 015818</p> <p>Sold by the foot.</p>			
14	000323	2	CLIP, HOSE CLAMP
15	606581	1	FUEL TANK
<p>Commenti per num parte 606581</p> <p>**IMPORTANT**</p> <p>Before replacing Fuel Tank, refer to Service Bulletin 550.</p>			
16	603807	1	CAP, 3.5" RATCHETING GAS
17	000331	9	WIRE TIE, SMALL/SHORT
18	706531	2	GM 1.12X1.75X1.37X.12
19	604307	3	MOUNT, PUSH BUTTON
20	047456	1	GM .750X.188X1.00X.12
21	601503	2	CB .250-20 X .625 ZNYC
22	080358	1	GM .50X1.00X.75X.12
23	016816	2	NT .250-20FLKG5
24	124348-1	1	TANK NECK SUPPORT
25	781880	2	BUMPER, .500x 1.00x .31
26	605542	1	ISOLATOR
27	016832	1	NT .312-18FLKG5
28	602725	2	WIRE TIE,

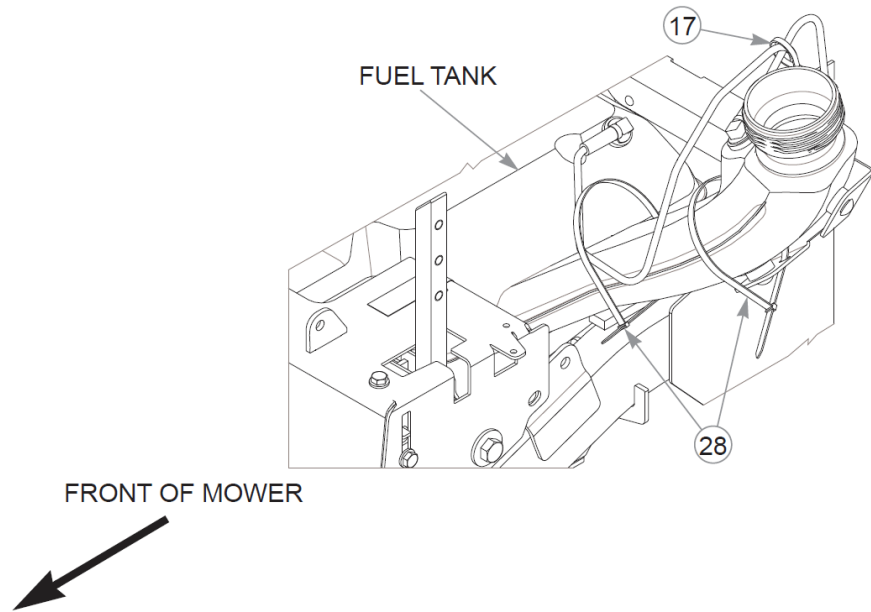
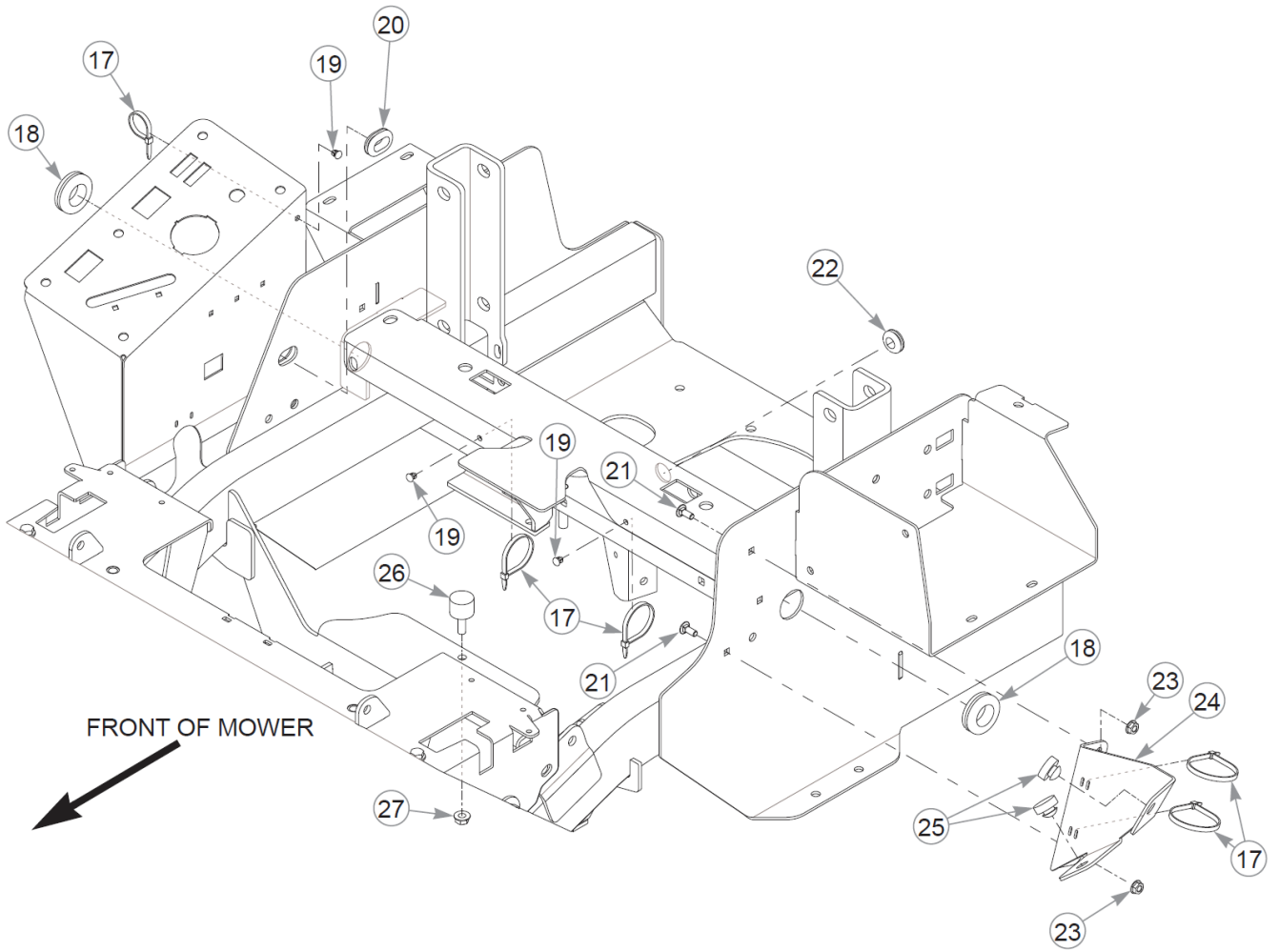

Pagina lasciata volutamente in bianco

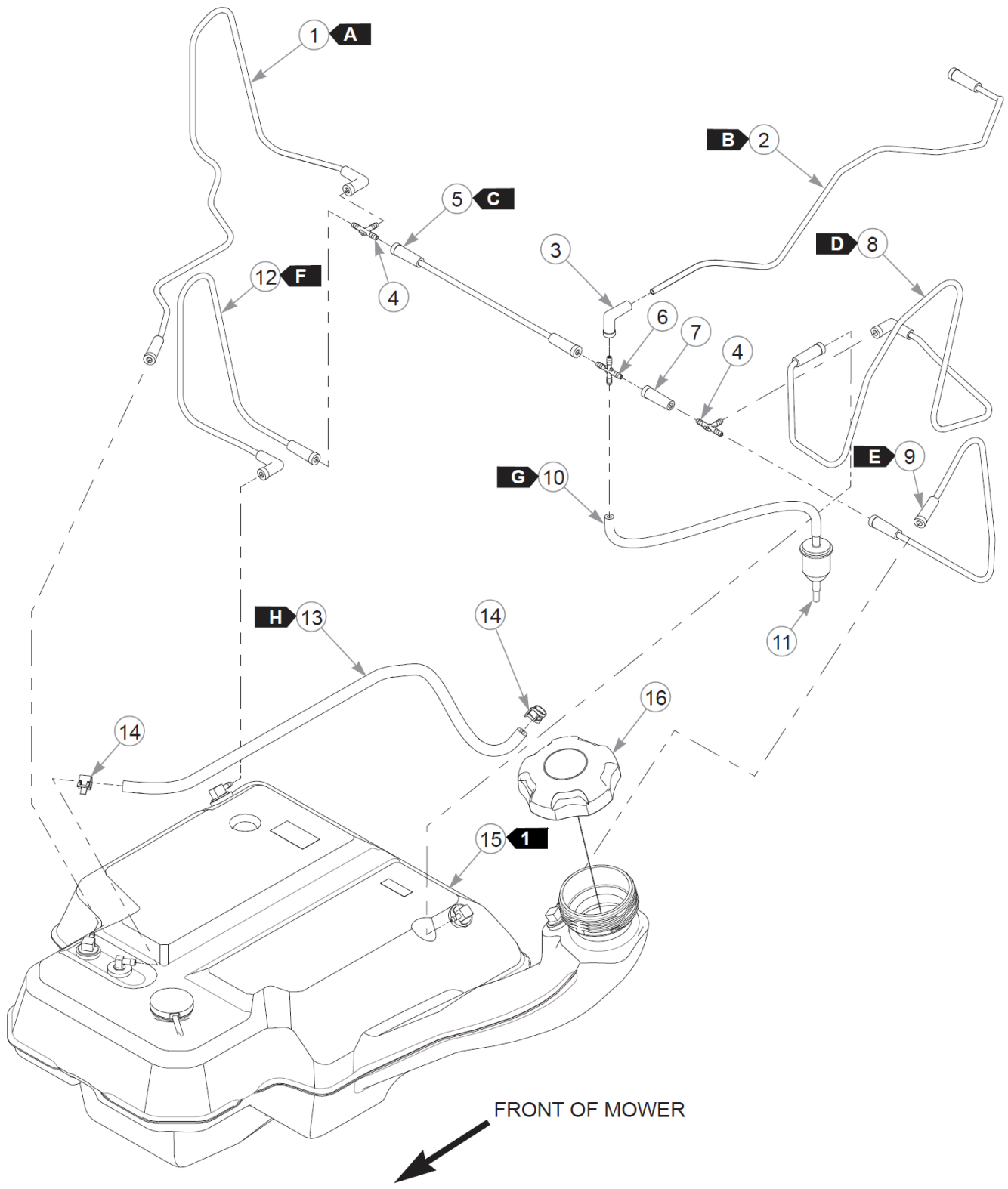

Elemento	Parte n.	Q.ta	Nome
1	605491	1	VAPOR LINE, 3/16 FORMED
2	605493	1	VAPOR LINE, 3/16 FORMED
3	605565	1	BOOT, 3/16 TO 3/16
4	605690	2	TEE, 3/16" PLASTIC
5	605535	1	VAPOR LINE, 3/16 FORMED
6	605425	1	CROSS, 3/16" PLASTIC
7	605564	1	BOOT, 3/16 TO 3/16
8	605534	1	VAPOR LINE, 3/16 FORMED
9	605492	1	VAPOR LINE, 3/16 FORMED
10	603326	31 cm	VAPOR LINE, 3/16"
<p>Commenti per num parte 603326</p> <p>Sold by the foot.</p>			
11	604323	1	FILTER, VAPOR SYSTEM
12	605533	1	VAPOR LINE, 3/16 FORMED
13	015818	53 cm	FUEL LINE, 1/4"
<p>Commenti per num parte 015818</p> <p>Sold by the foot.</p>			
14	000323	2	CLIP, HOSE CLAMP
15	606581	1	FUEL TANK
<p>Commenti per num parte 606581</p> <p>**IMPORTANT**</p> <p>Before replacing Fuel Tank, refer to Service Bulletin 550.</p>			
16	603807	1	CAP, 3.5" RATCHETING GAS
17	000331	9	WIRE TIE, SMALL/SHORT
18	602725	1	WIRE TIE,
19	604307	3	MOUNT, PUSH BUTTON
20	047456	1	GM .750X.188X1.00X.12
21	080358	1	GM .50X1.00X.75X.12
22	601503	4	CB .250-20 X .625 ZNYC
23	706531	2	GM 1.12X1.75X1.37X.12
24	016816	4	NT .250-20FLKG5
25	043570	2	CLIP - HOSE - SINGLE(FS)
26	124348-1	1	TANK NECK SUPPORT
27	781880	2	BUMPER, .500x 1.00x .31
28	605542	1	ISOLATOR
29	016832	1	NT .312-18FLKG5

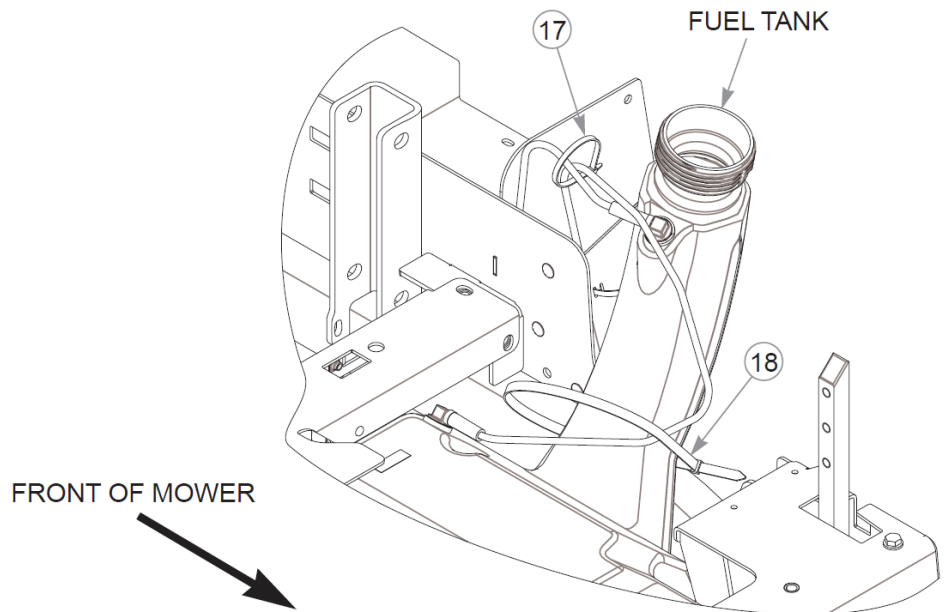
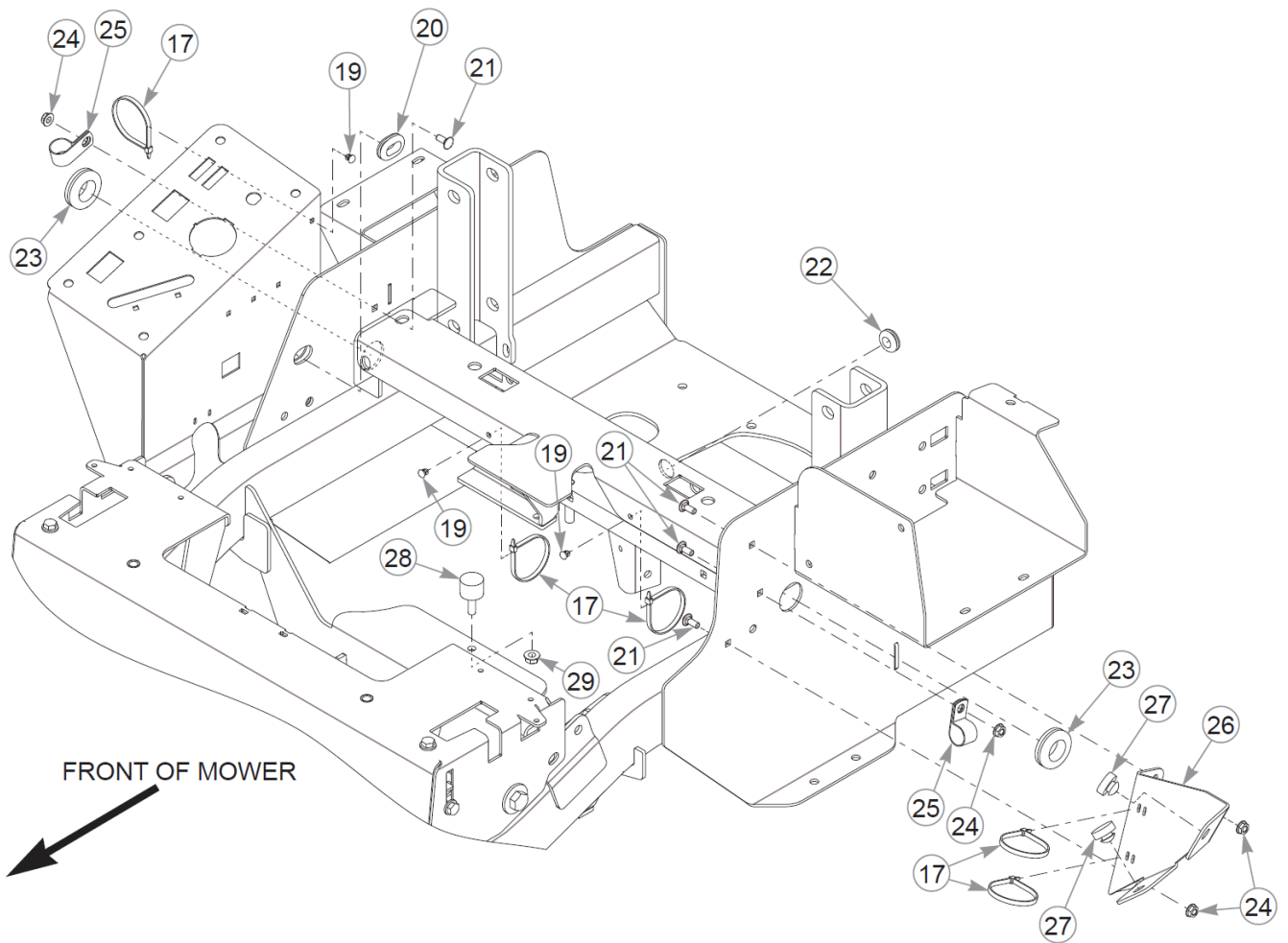

Comments for Page: Fuel System - S/N 18080150–18114074 (Multi-Page)

1. ****IMPORTANT****

Before replacing Fuel Tank, refer to Service Bulletin 550.

FUEL & VAPOR LINE LENGTHS

A: FRONT RIGHT SIDE PORT TO TEE (VAPOR)

B: ENGINE TO CROSS (VAPOR)

C: TEE TO CROSS (VAPOR)

D: LEFT BACK PORT TO TEE (VAPOR)

E: FILLER NECK PORT TO TEE (VAPOR)

F: RIGHT BACK PORT TO TEE (VAPOR)

G: 31 cm CROSS TO FILTER (VAPOR)

H: 53 cm TANK TO FUEL FILTER

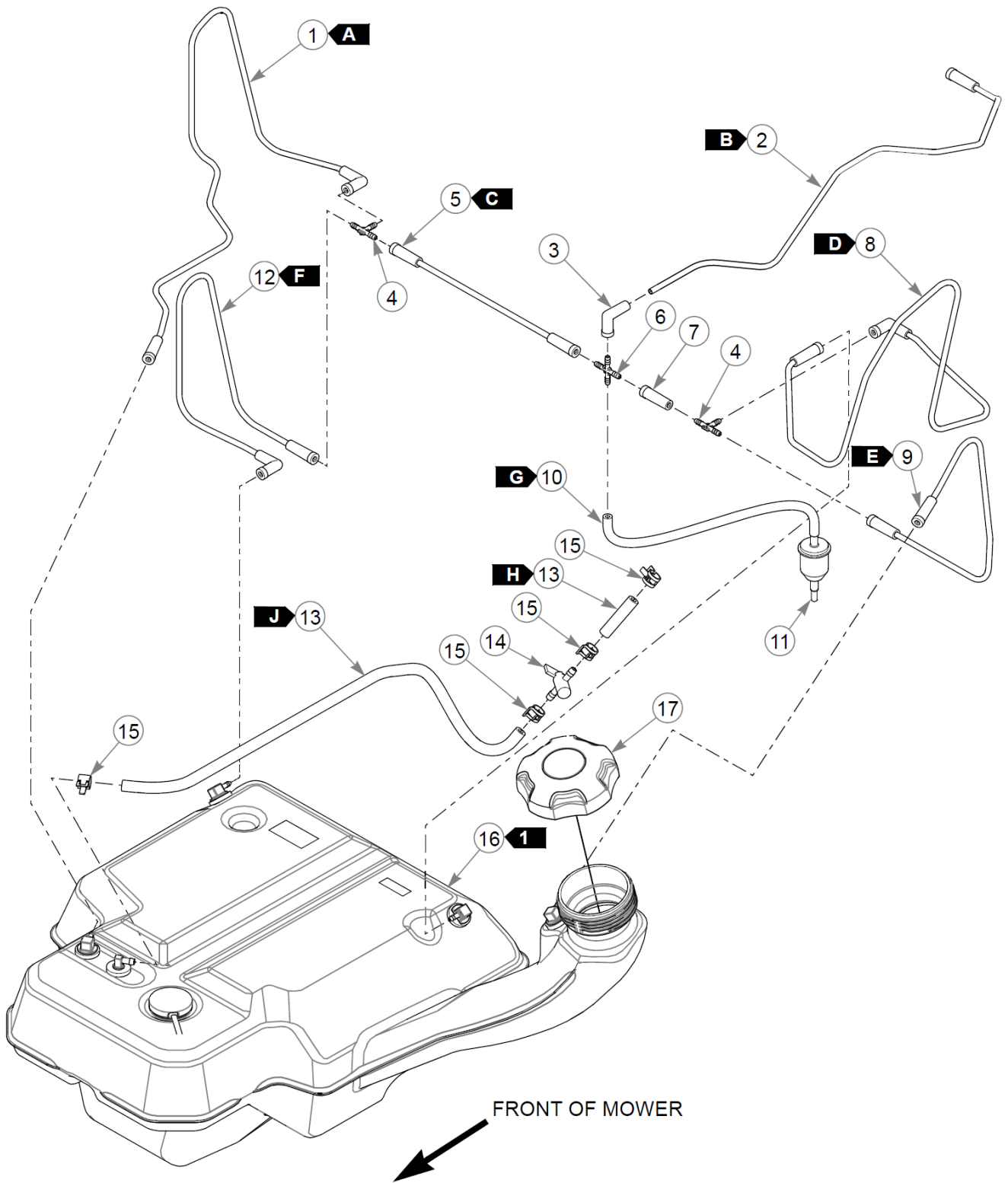

Elemento	Parte n.	Q.ta	Nome
1	605491	1	VAPOR LINE, 3/16 FORMED
2	605493	1	VAPOR LINE, 3/16 FORMED
3	605565	1	BOOT, 3/16 TO 3/16
4	605690	2	TEE, 3/16" PLASTIC
5	605535	1	VAPOR LINE, 3/16 FORMED
6	605425	1	CROSS, 3/16" PLASTIC
7	605564	1	BOOT, 3/16 TO 3/16
8	605534	1	VAPOR LINE, 3/16 FORMED
9	605492	1	VAPOR LINE, 3/16 FORMED
10	603326	31 cm	VAPOR LINE, 3/16"
<p>Commenti per num parte 603326</p> <p>Sold by the foot.</p>			
11	604323	1	FILTER, VAPOR SYSTEM
12	605533	1	VAPOR LINE, 3/16 FORMED
13	015818	61 cm	FUEL LINE, 1/4"
<p>Commenti per num parte 015818</p> <p>Sold by the foot.</p>			
14	605601	1	FUEL SHUT-OFF VALVE
15	000323	4	CLIP, HOSE CLAMP
16	606581	1	FUEL TANK
<p>Commenti per num parte 606581</p> <p>**IMPORTANT** Before replacing Fuel Tank, refer to Service Bulletin 550.</p>			
17	603807	1	CAP, 3.5" RATCHETING GAS
18	000331	8	WIRE TIE, SMALL/SHORT
19	602725	1	WIRE TIE,
20	604307	3	MOUNT, PUSH BUTTON
21	047456	1	GM .750X.188X1.00X.12
22	080358	1	GM .50X1.00X.75X.12
23	601503	4	CB .250-20 X .625 ZNYC
24	706531	2	GM 1.12X1.75X1.37X.12
25	016816	4	NT .250-20FLKG5
26	043570	2	CLIP - HOSE - SINGLE(FS)
27	124348-1	1	TANK NECK SUPPORT
28	781880	2	BUMPER, .500x 1.00x .31
29	605542	1	ISOLATOR

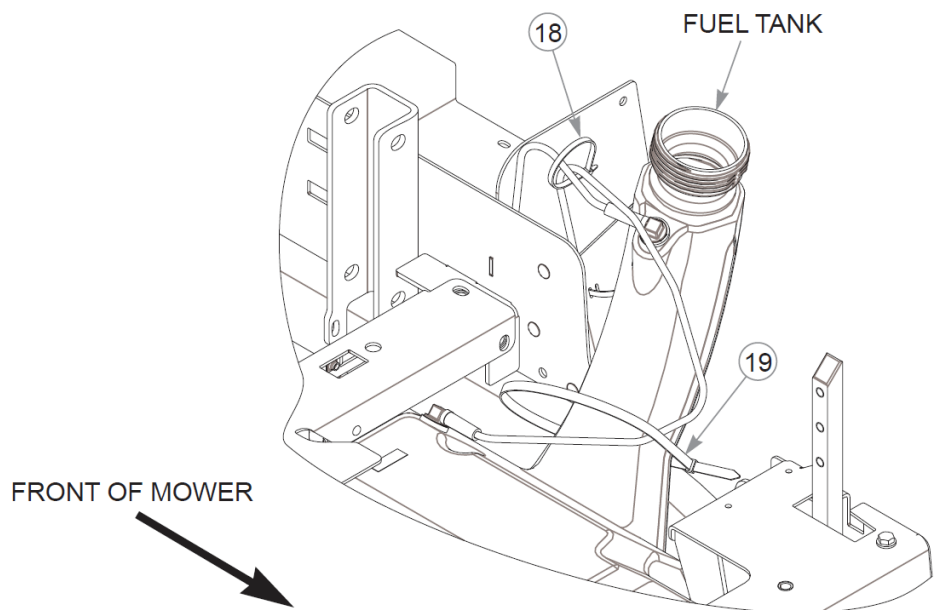
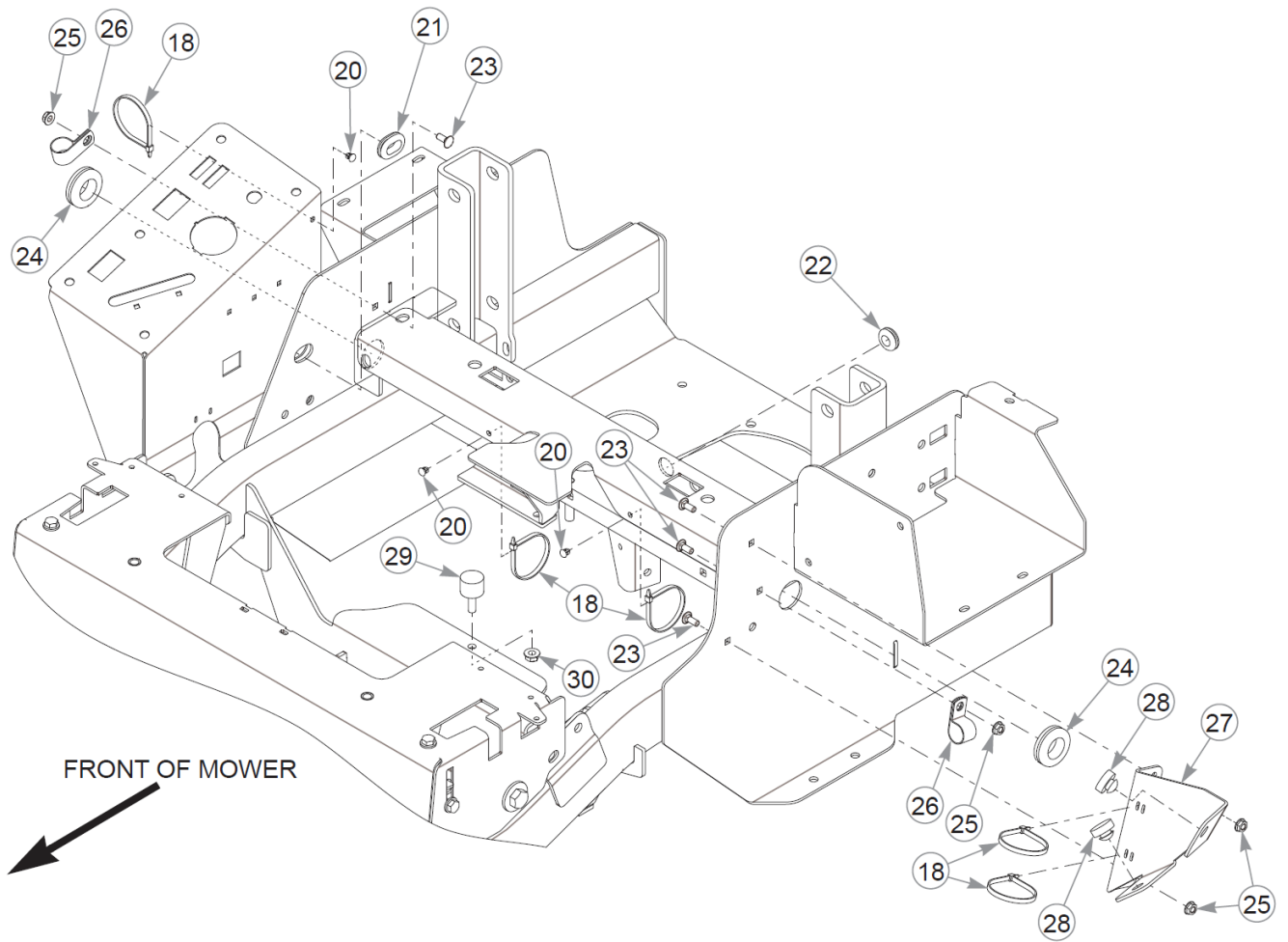

Elemento	Parte n.	Q.ta	Nome
30	016832	1	NT .312-18FLKG5
31	000430	1	WIRE TIE, SMALL/LONG

Comments for Page: Fuel System - S/N Prior to 18080150 (Multi-Page)

1. ****IMPORTANT****

Before replacing Fuel Tank, refer to Service Bulletin 550.

FUEL & VAPOR LINE LENGTHS

A: FRONT RIGHT SIDE PORT TO TEE (VAPOR)

B: ENGINE TO CROSS (VAPOR)

C: TEE TO CROSS (VAPOR)

D: LEFT BACK PORT TO TEE (VAPOR)

E: FILLER NECK PORT TO TEE (VAPOR)

F: RIGHT BACK PORT TO TEE (VAPOR)

G: 31 cm CROSS TO FILTER (VAPOR)

H: 5 cm VALVE TO ENGINE (FUEL)

J: 56 cm TANK TO VALVE (FUEL)

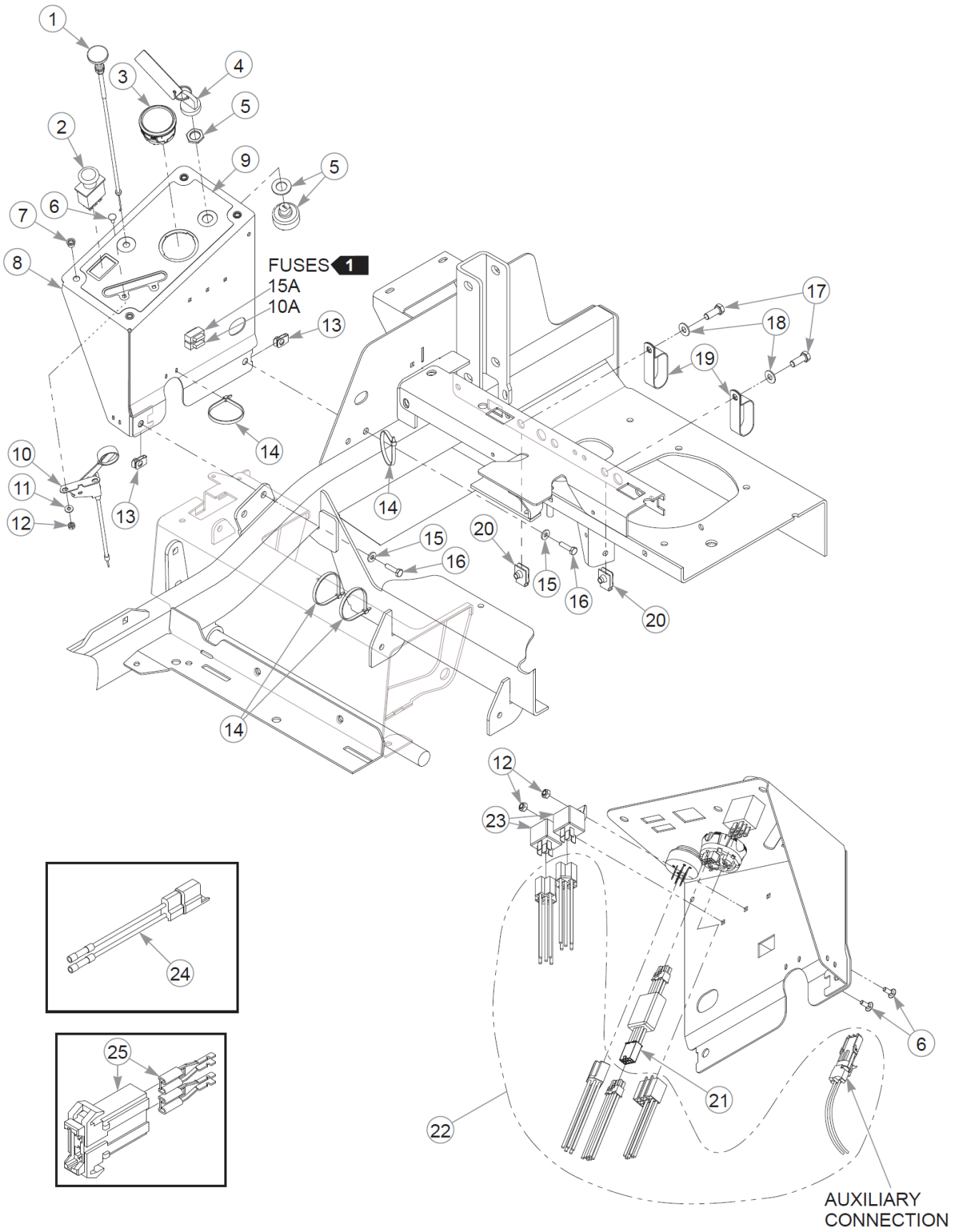

Elemento	Parte n.	Q.ta	Nome
1	786657	1	CABLE, CHOKE
2	776476	1	SWITCH, PTO 6201-321
3	605483	1	GAUGE, FUEL/HOURMETER
4	785808	1	KEY ASSEMBLY
5	045898	1	IGNITION SWITCH
6	601098	4	CB 10-24 X .500 ZYNC
7	808477	4	RIVET NUT, 1/4-20 THREA
8	552854	1	INSTR PANEL (W/DECAL)
9	605604	1	DECAL, INST PANEL
10	778365	1	CABLE, THROTTLE
11	704932	2	FW 0.219X.50X.05 ZY
12	059832	4	NT #10-24 HX NL ZN
13	601982	2	CN .250-20X .150 MAX THK
14	000331	7	WIRE TIE, SMALL/SHORT
15	768515	2	FW 0.281SAE
16	056077	2	CS .250-20X1.000HXG5
17	036244	2	CS .375-16X1.00 HX G5 ZY
18	767954	2	FW 0.379X.82X.06 HD ZY
19	045088	2	HOSE CLAMP 1" (FS)
20	601758	2	CN .375-16x.200 MAX THK
21	605554	1	WIRE HARNESS ADAPTER
22	605457	1	WIRE HARNESS, FST/STT
23	601053	3	RELAY, SEALED W/BRACKET
24	114052	1	KIT, CLUTCH CONN. REP.
25	601047	1	HOLDER, FUSE

Comments for Page: Instrument Panel & Wire Harness

1. Part of the wire harness.
2. The instrument panel includes the decal.
3. The sealed relay includes a bracket.

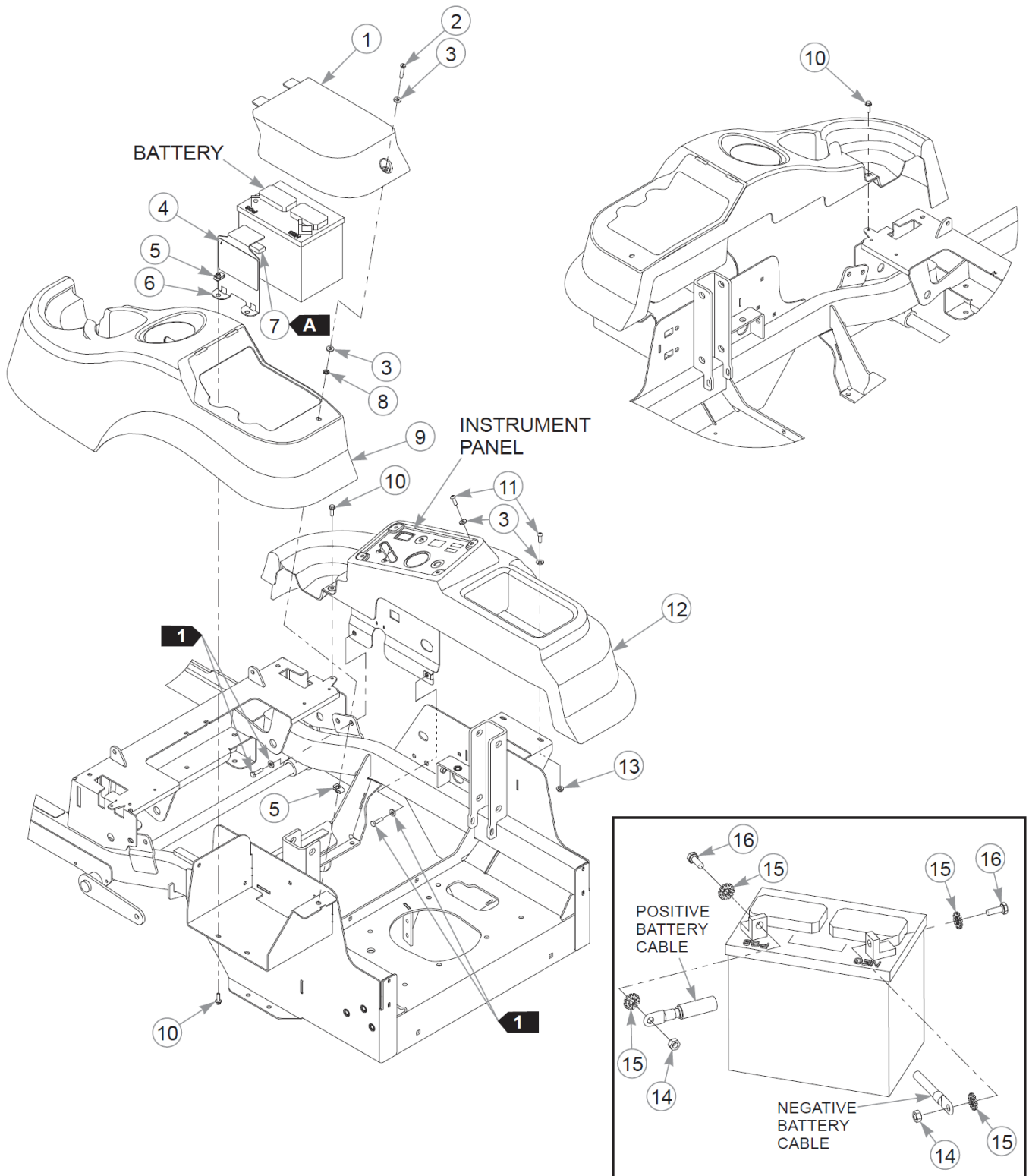

Fenders & Battery

Elemento	Parte n.	Q.ta	Nome
1	605558	1	FENDER LID
2	605627	1	CS .250-20 X 1.25 HX
3	605628	8	FW 0.281X.63X.07 ZB
4	601815	1	DECAL, BATTERY WARNINGS
5	601982	3	CN .250-20X .150 MAX THK
6	552858	1	BATTERY HOLD DOWN
7	713198	6 cm	SEAL 3/8x3/4 SOLD BY FT
8	605629	1	UNTHREADED PN 0.250 ID
9	605522	1	LH FENDER
<p>Commenti per num parte 605522</p> <p>The 'decal' which is on this fender is an 'in-mold label' and not available for purchase separately.</p>			
10	604324	4	CS .250-20 X .75 HX FLG
11	605473	6	CS .250-20X0.75 BH TX BZ
12	605521	1	RH FENDER
<p>Commenti per num parte 605521</p> <p>The 'decal' which is on this fender is an 'in-mold label' and not available for purchase separately.</p>			
13	016816	2	NT .250-20FLKG5
14	024927	2	NT .250-20HXG5
15	029868	4	LW .250 INTEXT ZY
16	055939	2	CS .250-20X0.75 HX G5 ZY

Comments for Page: Fenders & Battery

1. Part of the Instrument Panel assembly.
2. When performing service on the mower, disconnect the negative battery cable (black) and do not reconnect it to the battery until ready to start the engine.
3. The battery hold down includes the seal and decal.

SEAL LENGTH

A : 6 cm

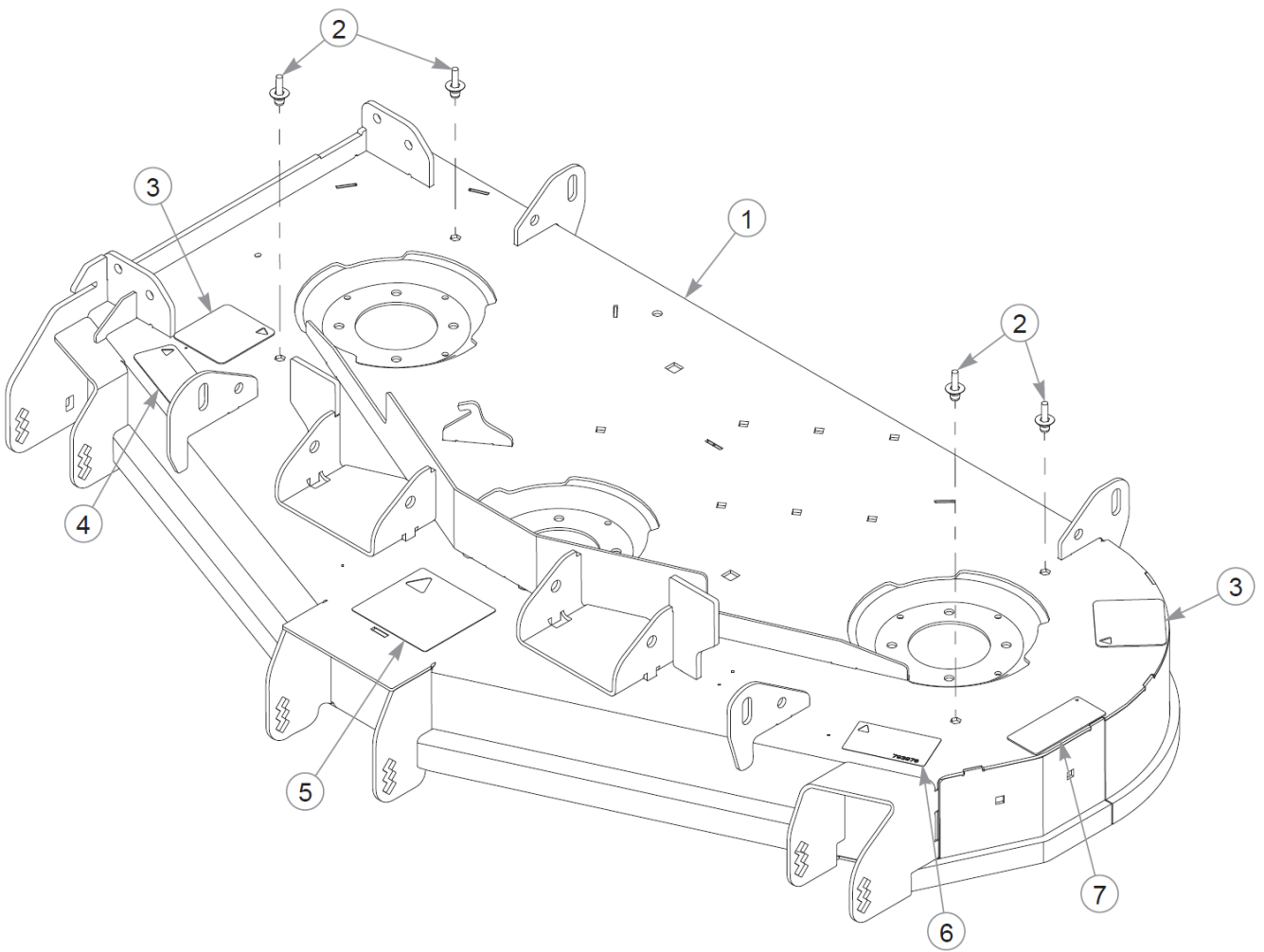

Service Deck

Elemento	Parte n.	Q.ta	Nome
1	554857	1	SVC, DECK DECAL
2	607583	4	0.25-20 X 0.625
3	601837	2	DECAL, DECK DANGERS
4	601624	1	DECAL, DISCHARGE CHUTE
5	781419	1	DECAL, BELT ROUTING
6	793976	1	DECAL, 48"DECK ID
7	601892	1	DECAL, THROWN OBJECTS

Comments for Page: Service Deck

1. The deck includes the decals and threaded studs.

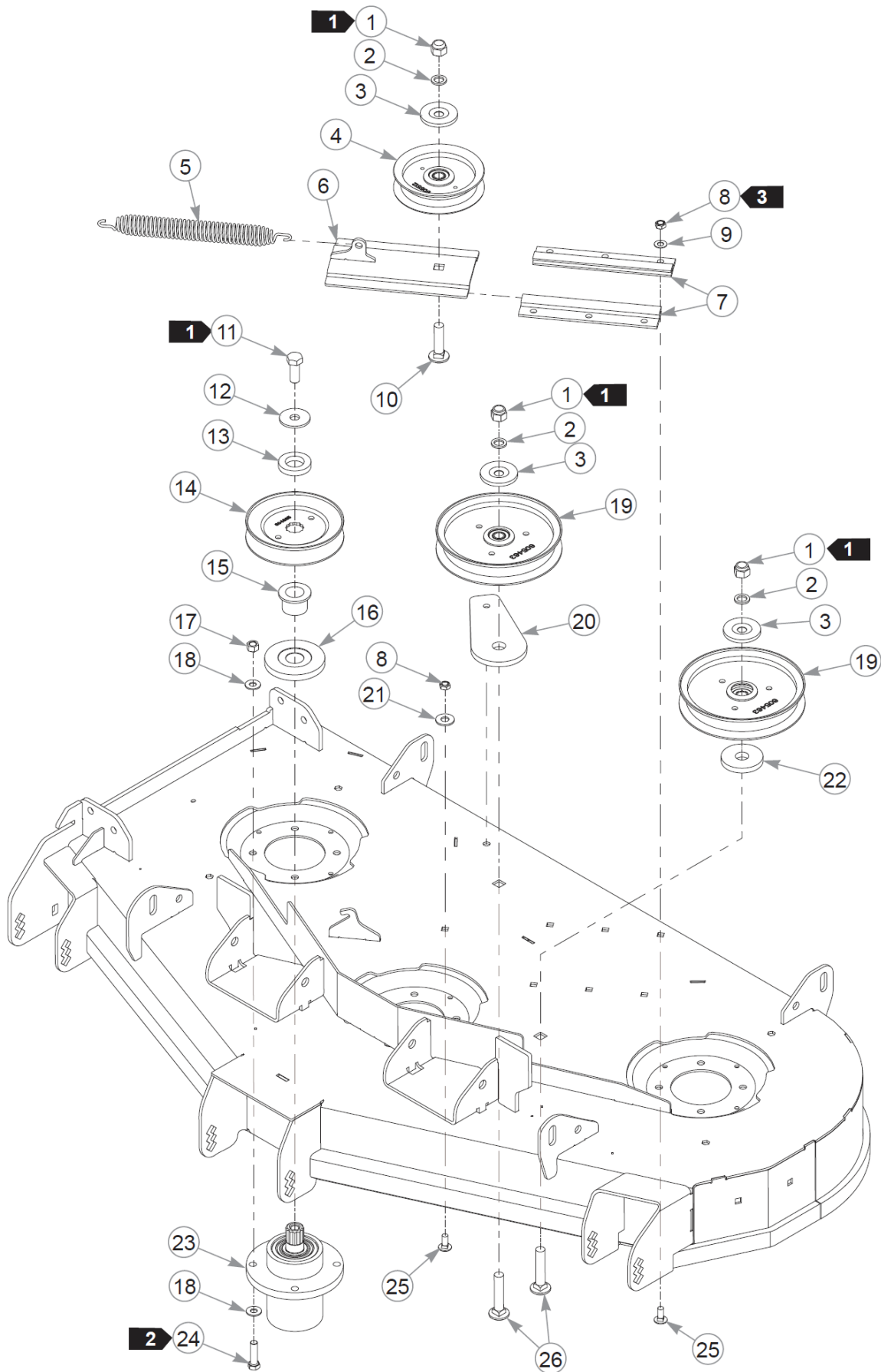

Deck Pulleys & Spindles

Elemento	Parte n.	Q.ta	Nome
1	781567	3	NT .500-13NLG5
2	604486	3	FW .531X.812X.089 HD
3	605467	3	DUST SHIELD
4	605512	1	4" IDLER PULLEY
5	122388	1	SPRING
6	121052	1	SLED, TENSIONER
7	604790	2	IDLER SLIDE, EXTRUDED
8	604251	7	NT .312-18 HXNL JAM G2ZN
9	604252	6	FW .340X.68X.04 ZY
10	604253	1	CB .50-13 X 2.00 STD ZN
11	705954	3	CS .500-13X1.25 HX G5 ZY
12	798603	3	FW .515X1.65X.12 HD ZY
13	604777	3	SPINDLE SPACER
14	604665	3	PULLEY, DECK DRIVE B-SEC
15	605504	3	SPACER, PULLEY
16	606362	3	DUST SHIELD
17	054502	12	NT .375-16HXG5
18	767954	24	FW 0.379X.82X.06 HD ZY
19	605463	2	6.00" IDLER PULLEY
20	605465	1	BASE, IDLER PULLEY MOUNT
21	017129	1	FW .440X1.00X0.08 ZY
22	605508	1	FW .73X2.25X.31 ZY
23	605380	3	SPINDLE ASSY, 12PT
24	005116	12	CS .375-16X1.38 HX G5 ZY
25	016253	7	CB .312-18X .750 FUL ZN
26	604254	2	CB .50-13 X 2.50 STD ZN

Comments for Page: Deck Pulleys & Spindles

1. Torque to 99 N•m.
2. Torque to 41 N•m.
3. Torque to 4–8 N•m.

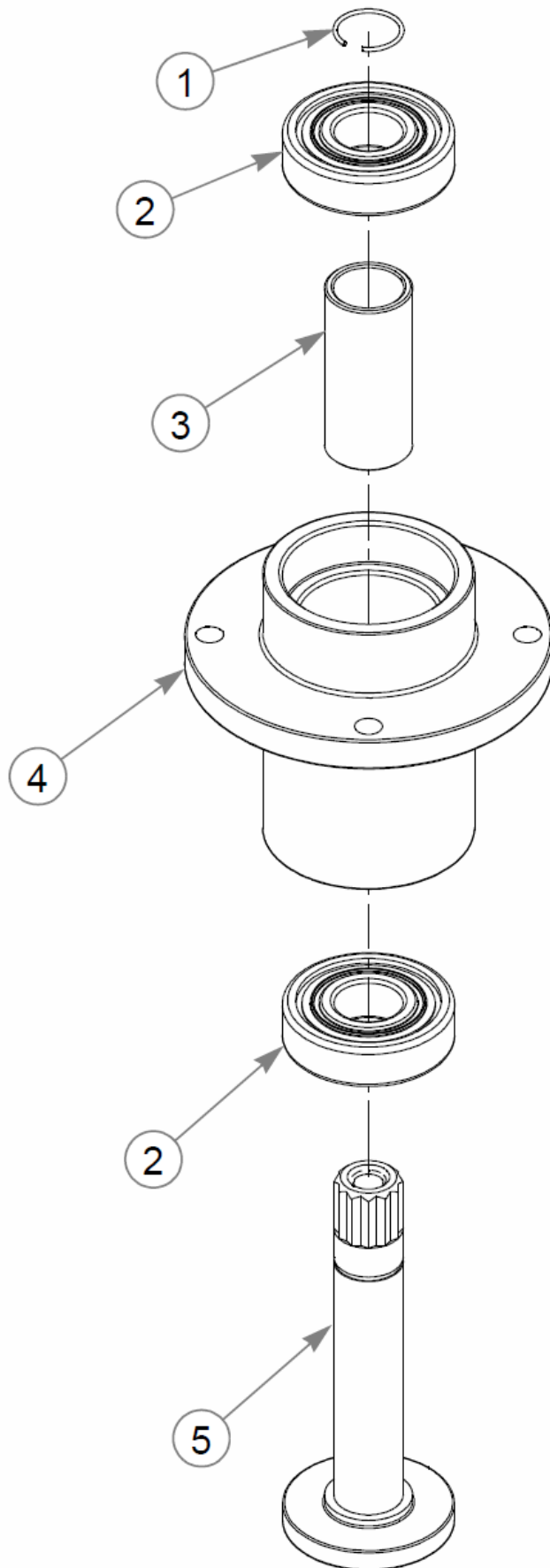

Elemento	Parte n.	Q.ta	Nome
1	783548	1	RING, BLADE SPINDLE RET
2	783555	2	BEARING, BLADE SPINDLE
3	783530	1	SPACER, BLADE SPINDLE
4	783514	1	HOUSING, BLADE SPINDLE
5	605381	1	SHAFT, SPINDLE, CONSUMER

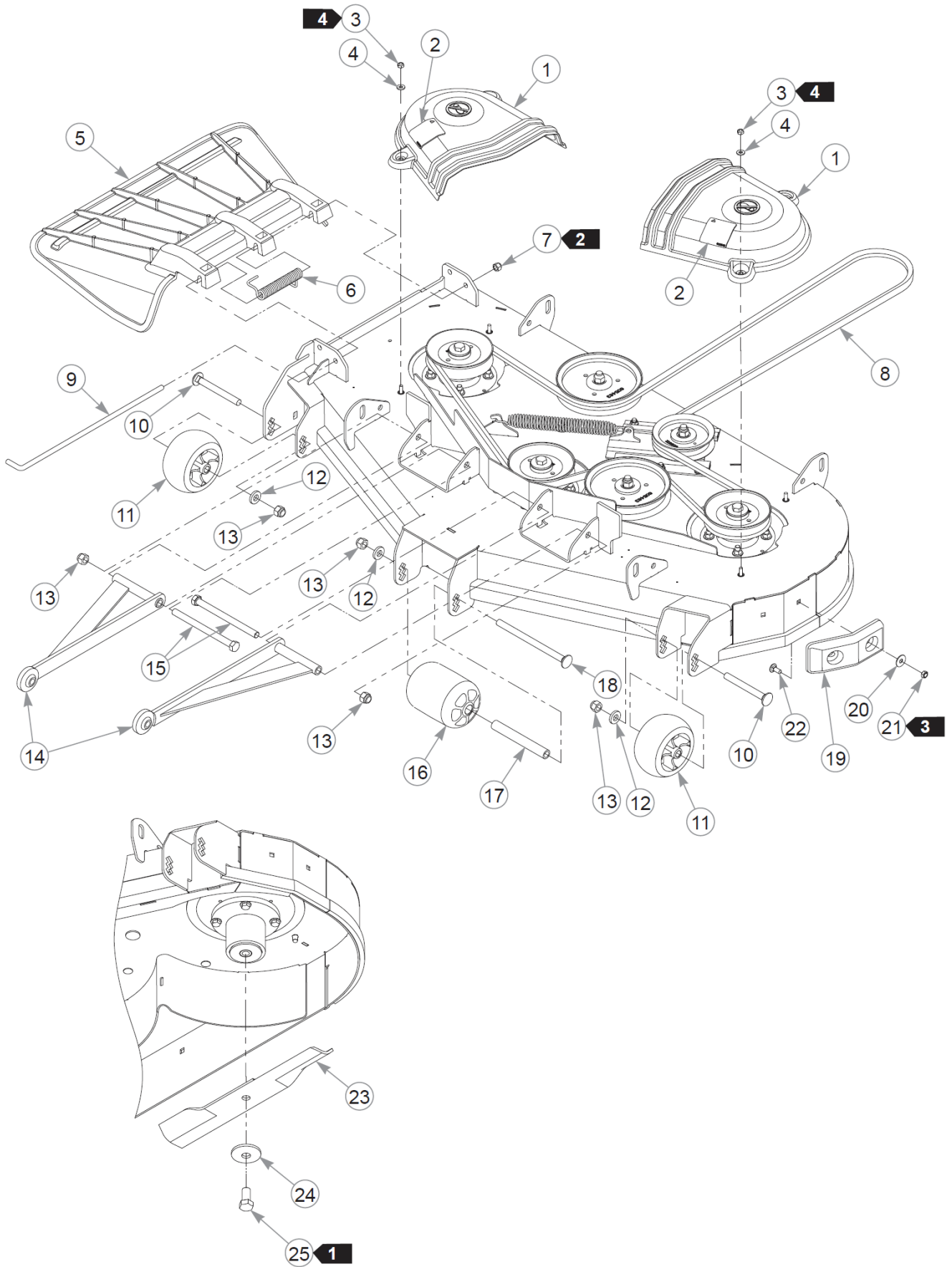

Elemento	Parte n.	Q.ta	Nome
1	553531	2	SVC PULLEY COVER,
2	602562	2	DECAL, NO SERVICE
3	068551	4	NT .250-20 HXZY NL
4	768515	4	FW 0.281SAE
5	605469	1	DISCHARGE CHUTE
6	602435	1	SPRING, TORSION
7	086660	1	NT .375-16NLG8
8	791335	1	BELT, B 143" EL
9	602432	1	PIN, CHUTE
10	602339	2	CB .50-13 X 4.50 STD ZN
11	604780	2	WHEEL, ANTI-SCALP
12	767962	3	FW .531 x 1.063 x .175
13	781567	5	NT .500-13NLG5
14	113717	2	PULLER W/A 14.53" C/C
15	042630	2	CS .500-13X6.500HXG5
16	602341	1	WHEEL, ANTI-SCALP
17	602344	1	SPACER, ANTI- SCALP 5.73
18	602338	1	CB .50-13 X 7.50 STD ZN
19	605376	1	DECK BUMPER
20	079210	2	FW 0.344X1.0X0.06 ZY
21	604251	2	NT .312-18 HXNL JAM G2ZN
22	016253	2	CB .312-18X .750 FUL ZN
23	606252	3	BLADE, 16.5"-H-F-CW
Not Shown	795757	3	BLADE, F16.50"-H-F-CW
Not Shown	601014	3	BLADE, F16.50"-L-F-CW
Not Shown	601123	3	BLADE, 16.50"-L-F-CW
Not Shown	796623	3	BLADE, 16.50"-MUL-F-CW
Not Shown	796631	3	BLADE, 16.50"-GAT-F-CW
24	782474	3	CW .678 X 2.250 X .187
25	781872	3	CS .625-11X1.250HXG5

Comments for Page: Deck Belt, Discharge Chute, Pulley Covers, & Blades

1. Torque to 160 N•m.
2. Do not torque; the discharge chute must pivot freely.
3. Torque to 4–8 N•m.
4. Torque to 3–5 N•m.

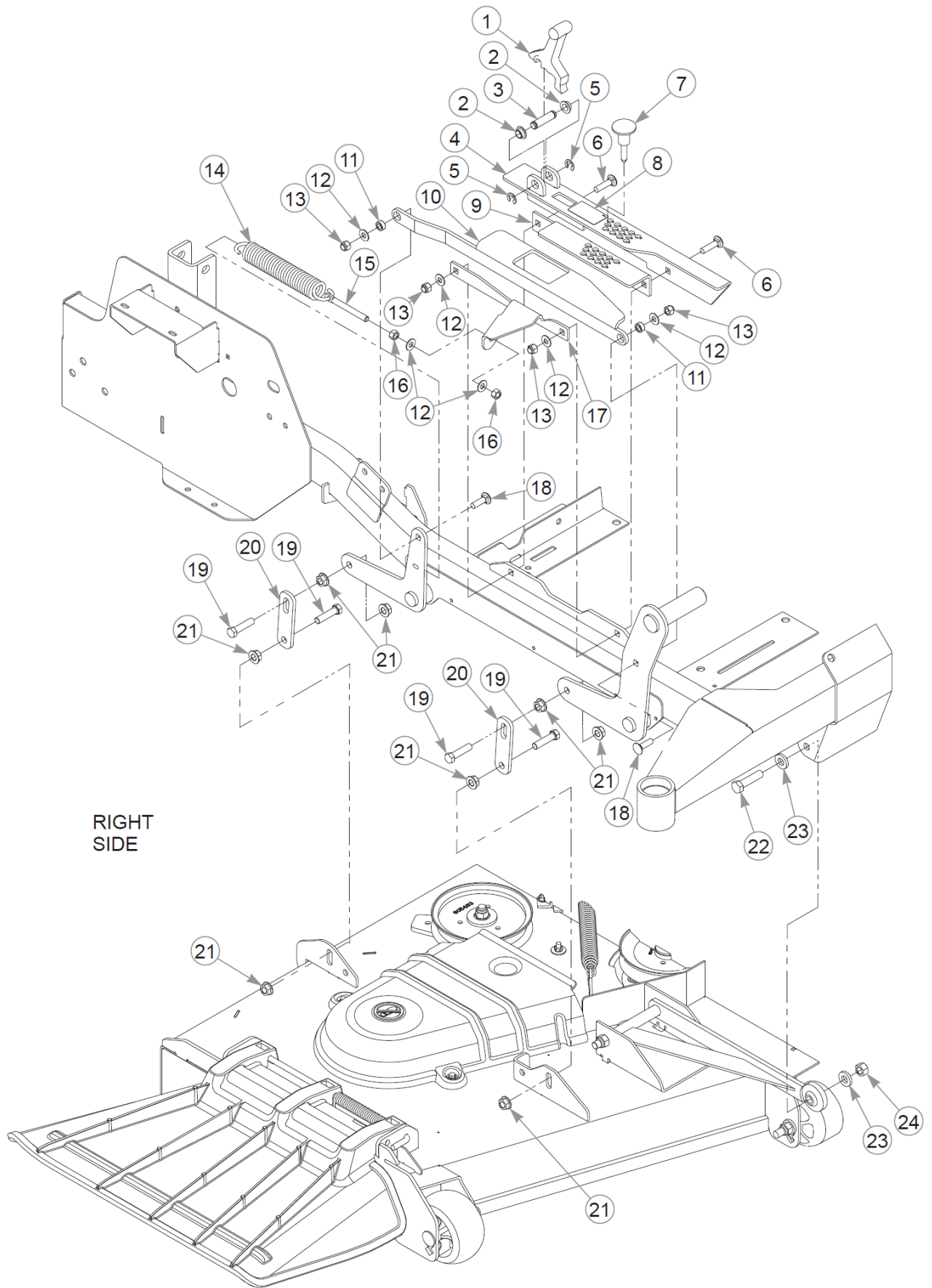

Elemento	Parte n.	Q.ta	Nome
1	605466	1	TRANSPORT LATCH
2	768259	2	BUSHING,IGUS#0810 (FS)
3	605470	1	CE .500X2.00X1.63
4	553089	1	INDICATOR PLATE CE
5	793059	2	CLIP E,(1/2").80X.396X.
6	710194	2	CB .375-16X 1.50 STD G5
7	607039	1	PIN, .375X1.62 MAGNETIC
8	605786	1	DECAL, DECK HEIGHT CE
9	119970	1	CUT HEIGHT BRKT, INNER
10	552859	1	INDICATOR PLATE
11	118900	2	SPACER, DECK LIFT LINK
12	767954	6	FW 0.379X.82X.06 HD ZY
13	086660	4	NT .375-16NLG8
14	008938	1	TENSION SPRING-PLATED
15	601486	1	EB, .375-16X3.00 FULTHD
16	054502	2	NT .375-16HXG5
17	120779	1	ASSIST SPRING BRKT
18	603113	2	CB .375-16X1.250 G5 ZNC
19	055749	8	CS .437-14X1.750HXG5
20	124354-1	4	DECK LIFT LINK
21	704643	16	NT .437-14FLKG5
22	078949	2	CS .500-13X2.000 FUL HX
23	767962	4	FW .531 x 1.063 x .175
24	008193	2	NT .500-13HXG5

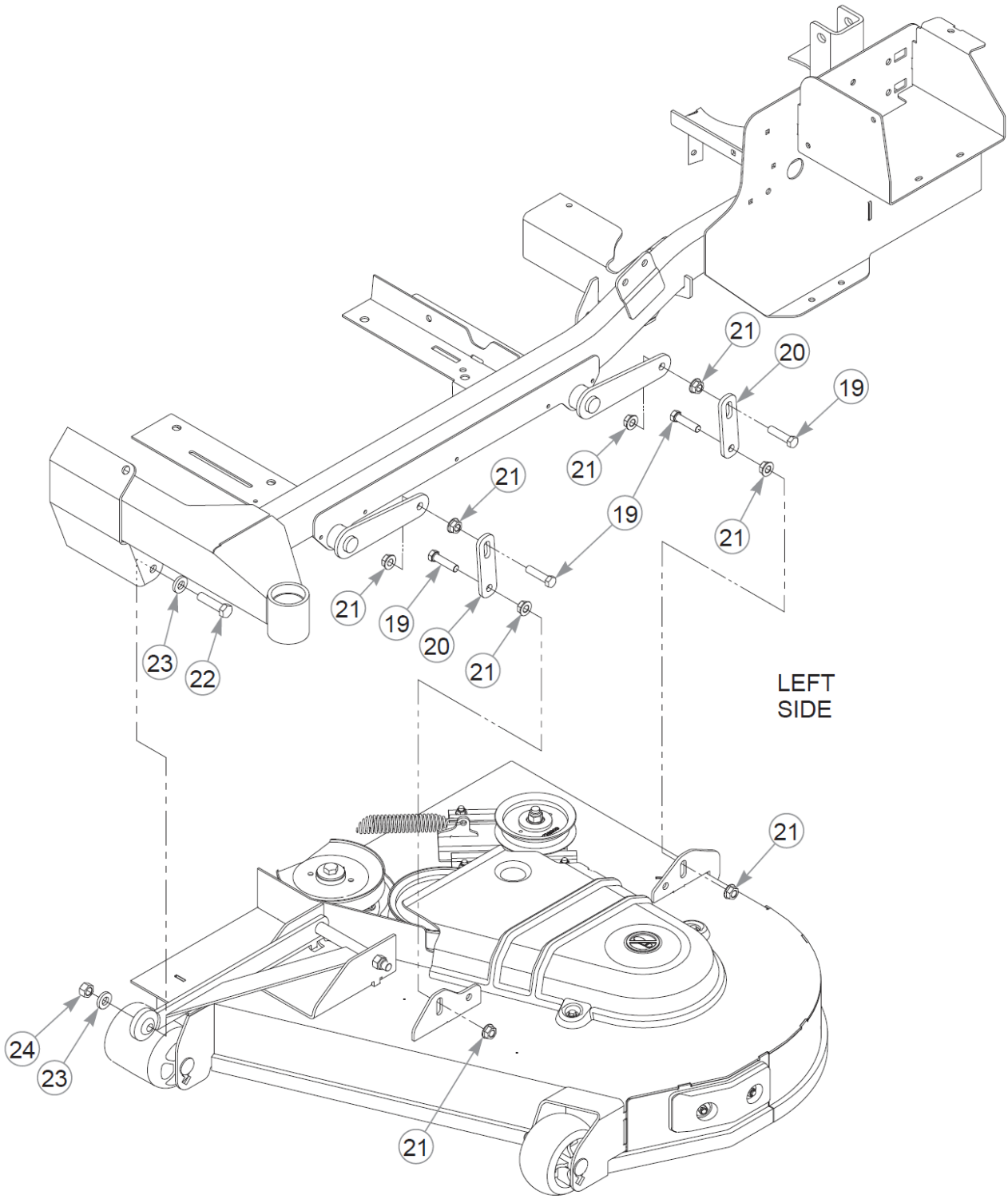

Comments for Page: Deck Lift & Deck Mounting Hardware (Multi-Page)

1. The indicator bracket includes the decal.

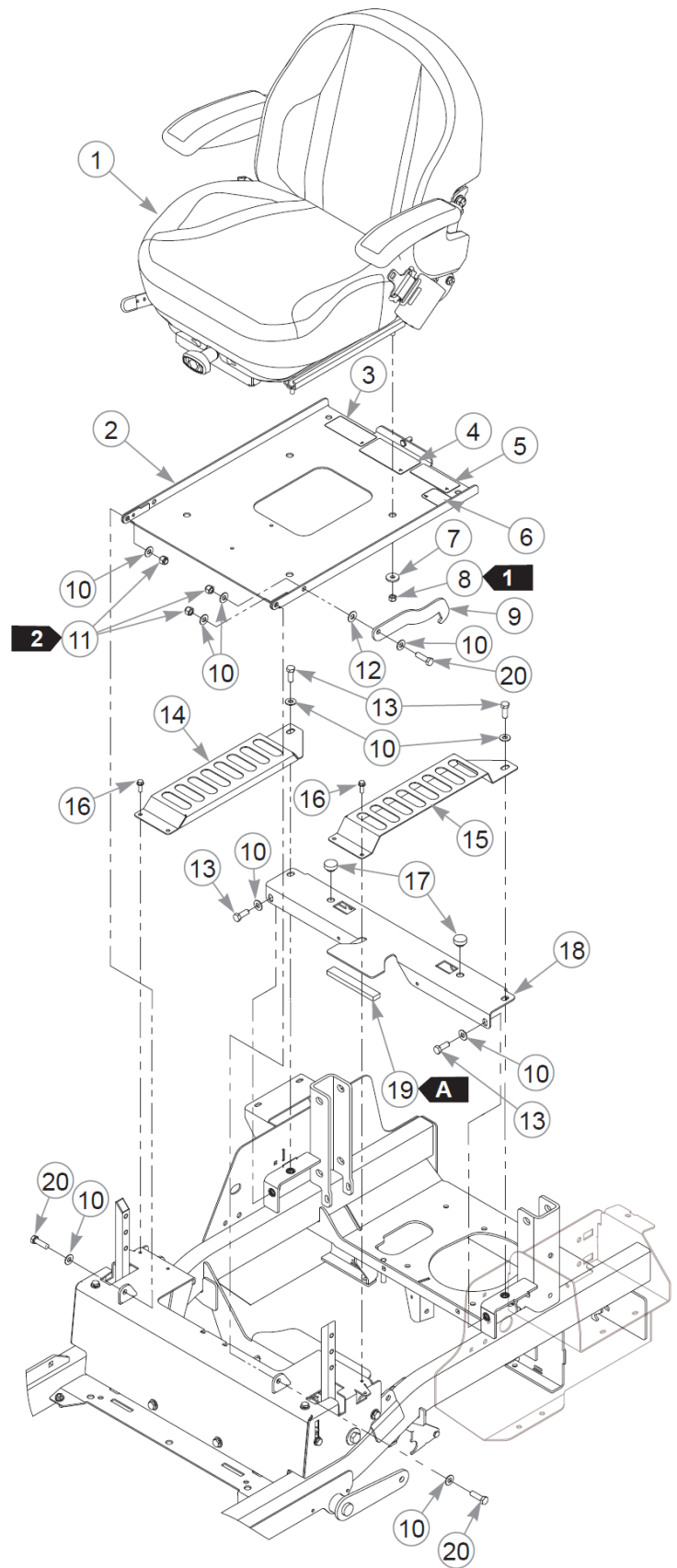
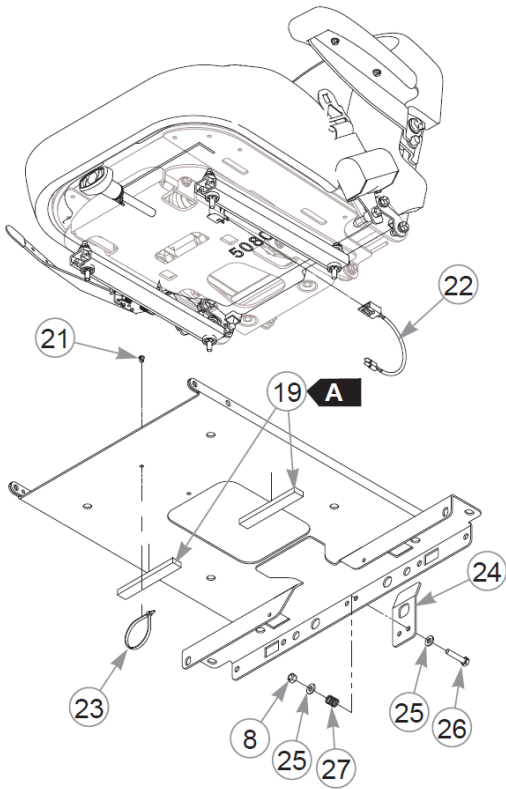

Seat

Elemento	Parte n.	Q.ta	Nome
1	607457	1	SEAT, SEATS INC 1110
2	554679	1	SVC SEAT PAN
3	601967	1	DECAL, ENGINE COMPART
4	600899	1	DECAL, PUMP BELT WARNING
5	779280	1	DECAL, HOT & HYD OIL
6	605782	1	DECAL, LEVEL FUEL BLOWM
7	712927	4	FW 0.344X1.00X.12 HD ZY
8	058776	6	NT .312-18NLG5
9	124558-4	1	SEAT STOP
10	767954	10	FW 0.379X.82X.06 HD ZY
11	086660	3	NT .375-16NLG8
12	724716	1	WASHER, FIBER (FS)
13	036244	4	CS .375-16X1.00 HX G5 ZY
14	123688-1	1	HYDRO GUARD, RH
15	123689-1	1	HYDRO GUARD, LH
16	604324	4	CS .250-20 X .75 HX FLG
17	781880	2	BUMPER, .500x 1.00x .31
18	552848	1	SEAT SUPPORT (WITH TAPE)
19	713198	38 cm	SEAL 3/8x3/4 SOLD BY FT
20	052860	3	CS .375-16X1.25 HX G5 ZY
21	604307	1	MOUNT, PUSH BUTTON
22	607088	1	JUMPER HARNESS
23	000331	1	WIRE TIE, SMALL/SHORT
24	124572-4	1	LATCH, SEAT
25	768523	4	FW 0.343SAE
26	756270	2	CS .312-18X1.500HXG5
27	607046	2	SPRING, COMPRESSION

Comments for Page: Seat

1. Torque to 23 N•m.
2. Do not torque; the seat pan and seat stop must rotate freely.
3. The seat pan includes the decals and seals. 4. The seat support includes the seal.

SEAL LENGTH

A : 13 cm

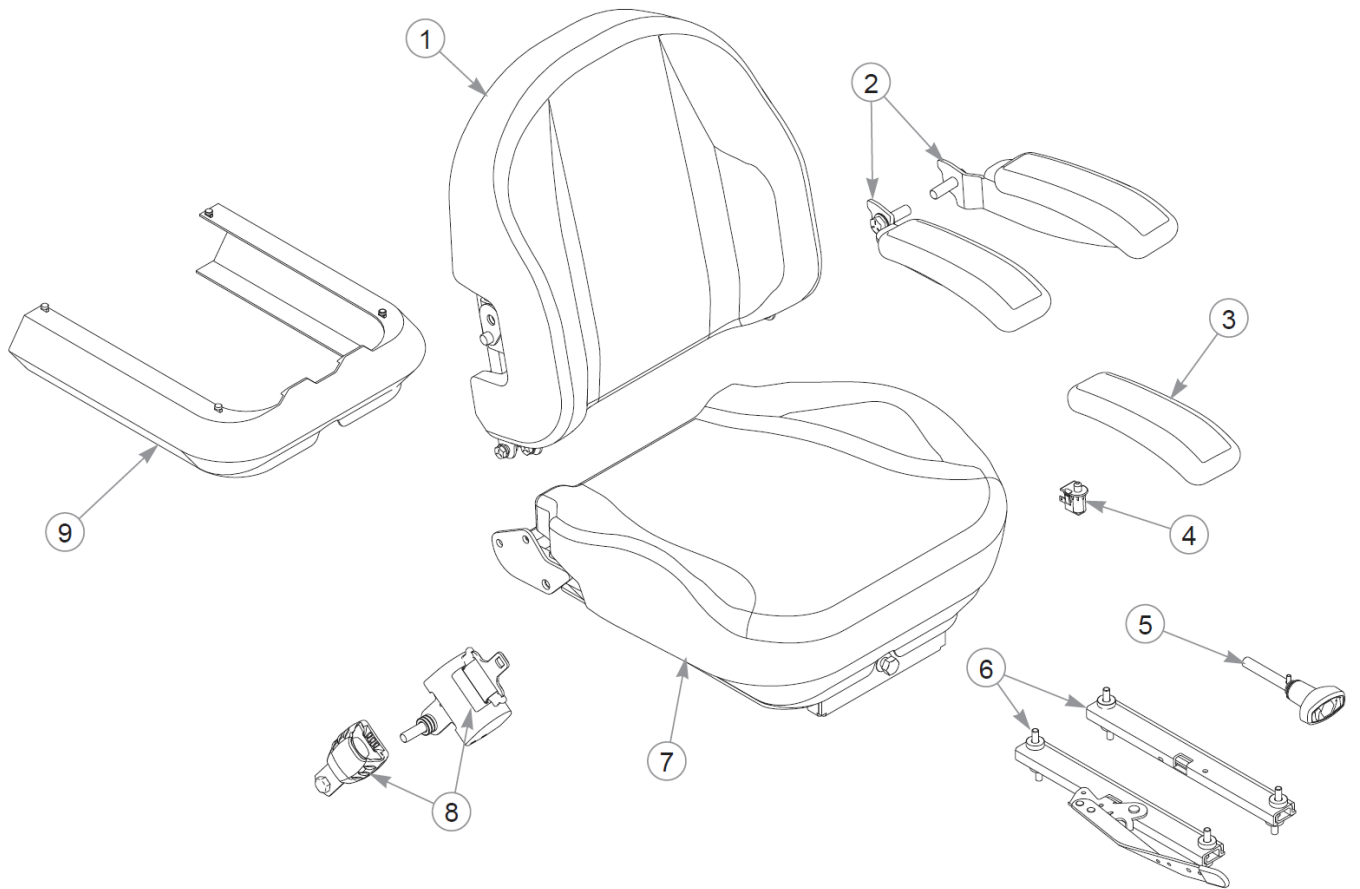

Seat Service Parts - 607457

48" FasTrak Parts Manual - 938704CE - HTFSTS048KAWFR691VC

Elemento	Parte n.	Q.ta	Nome
1	606078	1	SVC, BACK COVER
2	606081	1	SVC, ARM PADS
3	606080	2	SVC, ARMREST SET
4	606082	1	SVC, OPS
5	607214	1	SVC RIDE ADJUST KNOB
6	607459	1	SVC, SEAT TRACK KIT
7	607228	1	SVC, SEAT CUSHION COVER
8	607461	1	SVC, SEAT BELT KIT
9	607460	1	SVC, RUBBER BELLOW

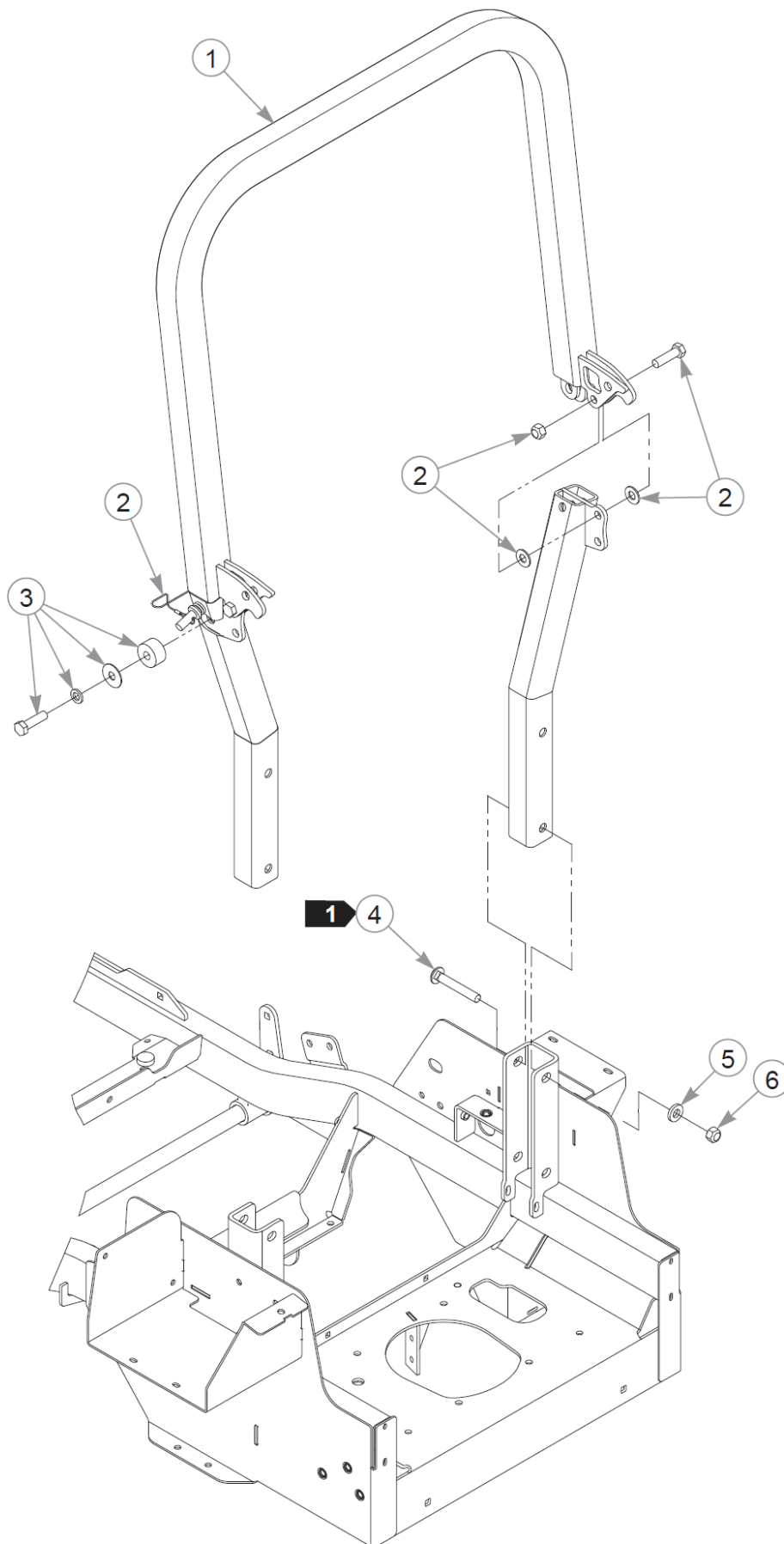

Elemento	Parte n.	Q.ta	Nome
1	605479	1	ROPS ASSY
2	605044	1	KIT, ROPS HARDWARE
3	605646	2	KIT, POLY STOP (PAIR)
4	607008	4	CB .50-13 X 3.25 GR5
5	767962	4	FW .531 x 1.063 x .175
6	023317	4	NT .500-13UNTG8

Comments for Page: ROPS

1. Torque to 99 N•m.